

**This electronic collection of documents is provided
for the convenience of the user
and is Not a Certified Document –**

**The documents contained herein were originally issued
and sealed by the individuals whose names and license
numbers appear on each page, on the dates appearing
with their signature on that page.**

**This file or an individual page
shall not be considered a certified document.**

29-NOV-2016 09:24
 S:\Dis+3\Macon\DN00547\topforrealign\dgn\title\DN00547_title_Rdy_dsn.dgn
 orbrown4 AT DI4CAD272166

09/08/99

CONTRACT: DN00547 TIP: SS-4914BO WBS ELEMENT: 43936.3.1; 2016CPT.14.03.10561.1

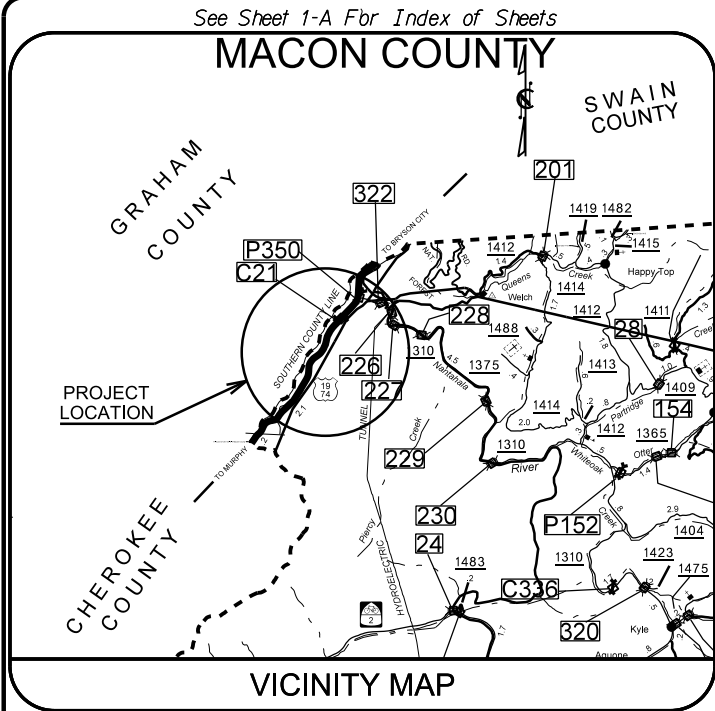

STATE OF NORTH CAROLINA
DIVISION OF HIGHWAYS

MACON COUNTY

LOCATION: ALONG NC HWY 19 /74 NEAR MACON/CHEROKEE COUNTY LINE
TYPE OF WORK: GRADING, PAVING, BOX CULVERT INSTALLATION, GUARDRAIL INSTALLATION

STATE	STATE PROJECT REFERENCE NO.	SHEET NO.	TOTAL SHEETS
N.C.	43936.3.1; 2016CPT.1.03.10561.1	1	
STATE PROJ. NO.	F.A. PROJ. NO.	DESCRIPTION	

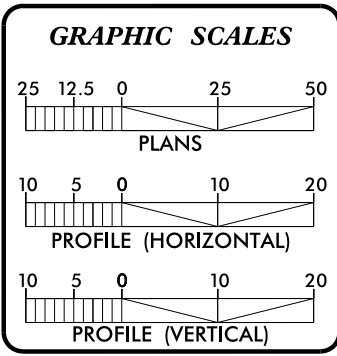
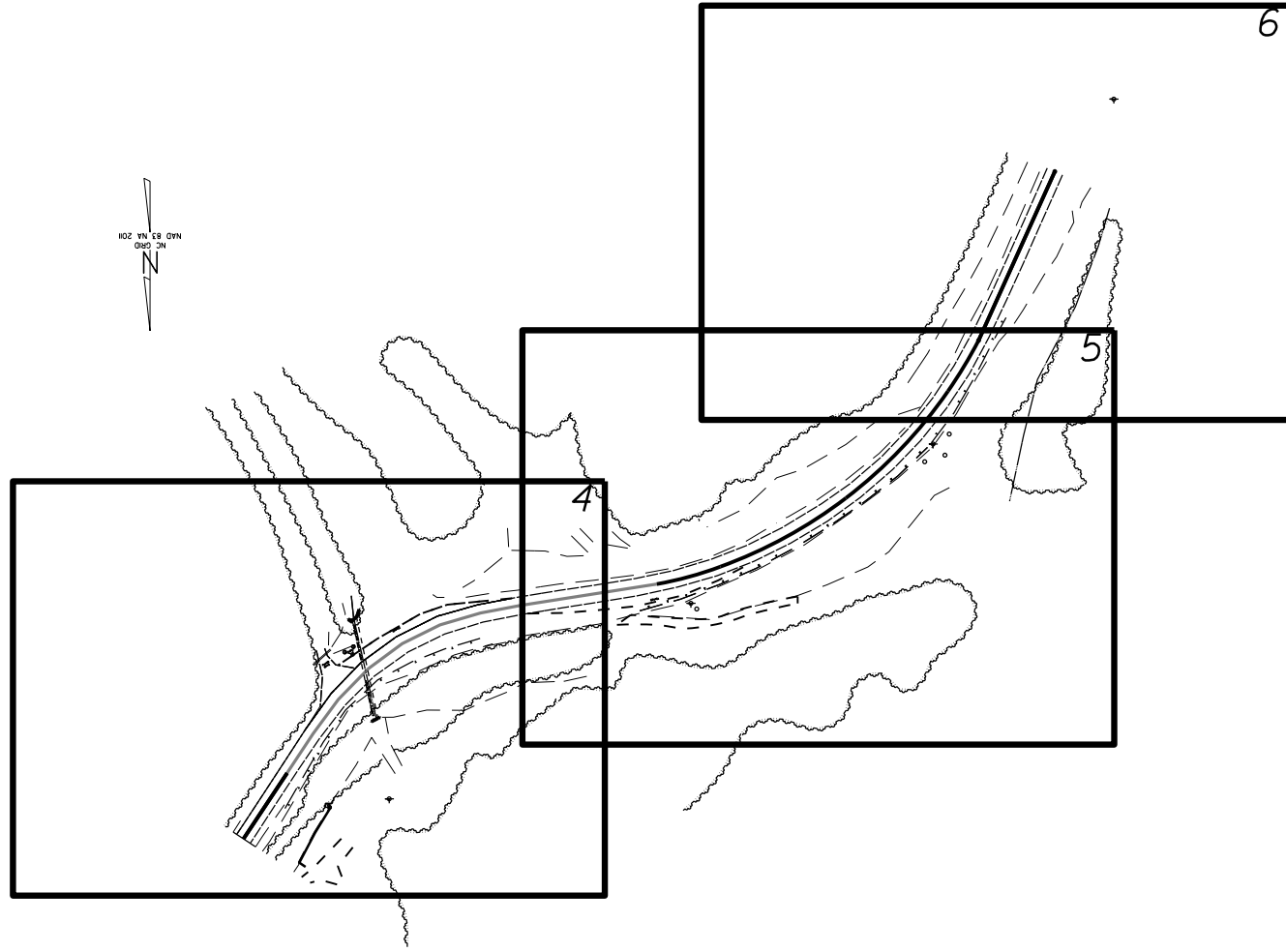

PROJECT LENGTH

0.46 MILES

Prepared in the Office of:
DIVISION OF HIGHWAYS
191 Robbinsville Rd., Andrews NC, 28901

2012 STANDARD SPECIFICATIONS	
RIGHT OF WAY DATE:	ANDY RUSSELL, P.E. <small>PROJECT ENGINEER</small>
LETTING DATE:	ALAN R BROWN <small>PROJECT DESIGN ENGINEER</small>

HYDRAULICS ENGINEER

SIGNATURE: _____ P.E.

ROADWAY DESIGN ENGINEER

SIGNATURE: _____ P.E.

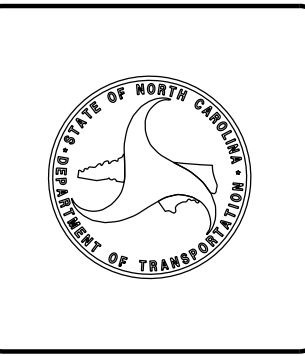

STATE OF NORTH CAROLINA
DIVISION OF HIGHWAYS

INDEX OF SHEETS

1	TITLE SHEET
2	INDEX OF SHEETS, GENERAL NOTES AND LIST OF STANDARDS
3	CONVENTIONAL SYMBOLS
3A	GUARDRAIL & EARTHWORK SUMMARY SHEET
3B-3C	TYPICAL SECTIONS
3D	BOX CULVERT DETAILS
3E	TEMPORARY STREAM DIVERSION DETAIL
4-6	PLAN SHEETS
EC1-EC10	EROSION CONTROL PLANS
C1	SURVEY CONTROL SHEET
S1-S4	STRIPING PLAN
X1-X26	CROSS SECTIONS
P1-P6	PROFILE SHEETS

GENERAL NOTES

- GENERAL NOTES: 2012 SPECIFICATIONS
EFFECTIVE: 01-17-2012
- CARE SHALL BE TAKEN TO PREVENT DAMAGE TO EXISTING UTILITIES DURING CONSTRUCTION. ANY DAMAGE TO THESE UTILITIES SHALL BE REPAIRED AT THE CONTRACTOR'S EXPENSE.
 - THE CONTRACTOR SHALL MAINTAIN THE SITE IN A MANNER SO THAT WORKMEN AND PUBLIC SHALL BE PROTECTED FROM INJURY.

LIST OF ROADWAY STANDARDS

2012 ROADWAY STANDARD DRAWINGS

The following Roadway Standards as appear in "Roadway Standard Drawings" - Highway Design Branch - N.C. Department of Transportation - Raleigh, N.C., dated January 17, 2012 and the latest revision thereto are applicable to this project and by reference hereby are considered a part of these plans.

STD. NO.	TITLE
DIVISION 2 - EARTHWORK	
200.03	Method of Clearing - Method III
225.02	Guide for Grading Subgrade
225.04	Method of Obtaining Superelevation
DIVISION 3 - PIPE CULVERTS	
300.01	Method of Pipe Installation
DIVISION 5 - SUBGRADE, BASES AND SHOULDERS	
560.01	Method of Shoulder Construction
DIVISION 7 - CONCRETE PAVEMENTS AND SHOULDERS	
700.05	Tying Proposed Pavement to Existing Pavement
DIVISION 8 - INCIDENTALS	
862.01	Guardrail Placement
862.02	Guardrail Installation
862.03	Structure Anchor Units
DIVISION II - WORK ZONE TRAFFIC CONTROL	
1101.01	Detail Drawing for Two Way Undivided Work Zone Warning Signs
1101.02	Temporary Lane Closures
DIVISION 12 - PAVEMENT MARKINGS, MARKERS AND DELINEATION	
1205.01	Line Types and Offsets
DIVISION 16 - EROSION CONTROL AND ROADSIDE DEVELOPEMENT	
1605.01	Temporary Silt Fence
1606.01	Special Sediment Control Fence
1607.01	Gravel Construction Entrance
1631.01	Matting Installation
1640.01	Coir Fiber Baffle

12/05/11

Note: Not to Scale

*S.U.E. = *Subsurface Utility Engineering*

STATE OF NORTH CAROLINA
DIVISION OF HIGHWAYS

CONVENTIONAL PLAN SHEET SYMBOLS

BOUNDARIES AND PROPERTY:

State Line	-----
County Line	-----
Township Line	-----
City Line	-----
Reservation Line	-----
Property Line	-----
Existing Iron Pin	⊙
Property Corner	-----
Property Monument	⊠
Parcel/Sequence Number	Ⓣ
Existing Fence Line	-x-x-x-
Proposed Woven Wire Fence	○
Proposed Chain Link Fence	⊠
Proposed Barbed Wire Fence	◇
Existing Wetland Boundary	W.L.B.
Proposed Wetland Boundary	W.L.B.
Existing Endangered Animal Boundary	E.A.B.
Existing Endangered Plant Boundary	E.P.B.
Known Soil Contamination: Area or Site	☠ ☠
Potential Soil Contamination: Area or Site	☠ ?

BUILDINGS AND OTHER CULTURE:

Gas Pump Vent or U/G Tank Cap	○
Sign	⊙
Well	⊙
Small Mine	⊗
Foundation	⊠
Area Outline	⊠
Cemetery	⊠
Building	⊠
School	⊠
Church	⊠
Dam	⊠

HYDROLOGY:

Stream or Body of Water	-----
Hydro, Pool or Reservoir	⊠
Jurisdictional Stream	JS
Buffer Zone 1	BZ 1
Buffer Zone 2	BZ 2
Flow Arrow	←
Disappearing Stream	→
Spring	⊙
Wetland	⊗
Proposed Lateral, Tail, Head Ditch	⊠
False Sump	⊠

RAILROADS:

Standard Gauge	-----
RR Signal Milepost	⊙
Switch	⊠
RR Abandoned	-----
RR Dismantled	-----

RIGHT OF WAY:

Baseline Control Point	◇
Existing Right of Way Marker	△
Existing Right of Way Line	-----
Proposed Right of Way Line	-----
Proposed Right of Way Line with Iron Pin and Cap Marker	⊙
Proposed Right of Way Line with Concrete or Granite R/W Marker	⊙
Proposed Control of Access Line with Concrete C/A Marker	⊙
Existing Control of Access	⊙
Proposed Control of Access	⊙
Existing Easement Line	-----
Proposed Temporary Construction Easement	-----
Proposed Temporary Drainage Easement	TDE
Proposed Permanent Drainage Easement	PDE
Proposed Permanent Drainage / Utility Easement	DUE
Proposed Permanent Utility Easement	PUE
Proposed Temporary Utility Easement	TUE
Proposed Aerial Utility Easement	AUE
Proposed Permanent Easement with Iron Pin and Cap Marker	⊙

ROADS AND RELATED FEATURES:

Existing Edge of Pavement	-----
Existing Curb	-----
Proposed Slope Stakes Cut	-----
Proposed Slope Stakes Fill	-----
Proposed Curb Ramp	Ⓢ
Existing Metal Guardrail	-----
Proposed Guardrail	-----
Existing Cable Guiderail	-----
Proposed Cable Guiderail	-----
Equality Symbol	⊕
Pavement Removal	⊠

VEGETATION:

Single Tree	⊙
Single Shrub	⊙
Hedge	-----
Woods Line	-----

Orchard	⊙
Vineyard	⊠

EXISTING STRUCTURES:

MAJOR:	
Bridge, Tunnel or Box Culvert	CONC
Bridge Wing Wall, Head Wall and End Wall	CONC WW
MINOR:	
Head and End Wall	CONC HW
Pipe Culvert	-----
Footbridge	-----
Drainage Box: Catch Basin, DI or JB	CB
Paved Ditch Gutter	-----
Storm Sewer Manhole	⊙
Storm Sewer	S

UTILITIES:

POWER:	
Existing Power Pole	⊙
Proposed Power Pole	⊙
Existing Joint Use Pole	⊙
Proposed Joint Use Pole	⊙
Power Manhole	⊙
Power Line Tower	⊠
Power Transformer	⊠
U/G Power Cable Hand Hole	⊙
H-Frame Pole	⊙
Recorded U/G Power Line	P
Designated U/G Power Line (S.U.E.*)	P

TELEPHONE:

Existing Telephone Pole	⊙
Proposed Telephone Pole	⊙
Telephone Manhole	⊙
Telephone Booth	⊠
Telephone Pedestal	⊠
Telephone Cell Tower	⊙
U/G Telephone Cable Hand Hole	⊙
Recorded U/G Telephone Cable	T
Designated U/G Telephone Cable (S.U.E.*)	T
Recorded U/G Telephone Conduit	TC
Designated U/G Telephone Conduit (S.U.E.*)	TC
Recorded U/G Fiber Optics Cable	T FO
Designated U/G Fiber Optics Cable (S.U.E.*)	T FO

WATER:

Water Manhole	⊙
Water Meter	⊙
Water Valve	⊙
Water Hydrant	⊙
Recorded U/G Water Line	-----
Designated U/G Water Line (S.U.E.*)	-----
Above Ground Water Line	A/G Water

TV:

TV Satellite Dish	⊙
TV Pedestal	⊠
TV Tower	⊙
U/G TV Cable Hand Hole	⊙
Recorded U/G TV Cable	TV
Designated U/G TV Cable (S.U.E.*)	TV
Recorded U/G Fiber Optic Cable	TV FO
Designated U/G Fiber Optic Cable (S.U.E.*)	TV FO

GAS:

Gas Valve	◇
Gas Meter	⊙
Recorded U/G Gas Line	G
Designated U/G Gas Line (S.U.E.*)	G
Above Ground Gas Line	A/G Gas

SANITARY SEWER:

Sanitary Sewer Manhole	⊙
Sanitary Sewer Cleanout	⊙
U/G Sanitary Sewer Line	SS
Above Ground Sanitary Sewer	A/G Sanitary Sewer
Recorded SS Forced Main Line	FSS
Designated SS Forced Main Line (S.U.E.*)	FSS

MISCELLANEOUS:

Utility Pole	⊙
Utility Pole with Base	⊠
Utility Located Object	⊙
Utility Traffic Signal Box	⊠
Utility Unknown U/G Line	U/UL
U/G Tank; Water, Gas, Oil	⊠
Underground Storage Tank, Approx. Loc.	UST
A/G Tank; Water, Gas, Oil	⊠
Geoenvironmental Boring	⊙
U/G Test Hole (S.U.E.*)	⊙
Abandoned According to Utility Records	AATUR
End of Information	E.O.I.

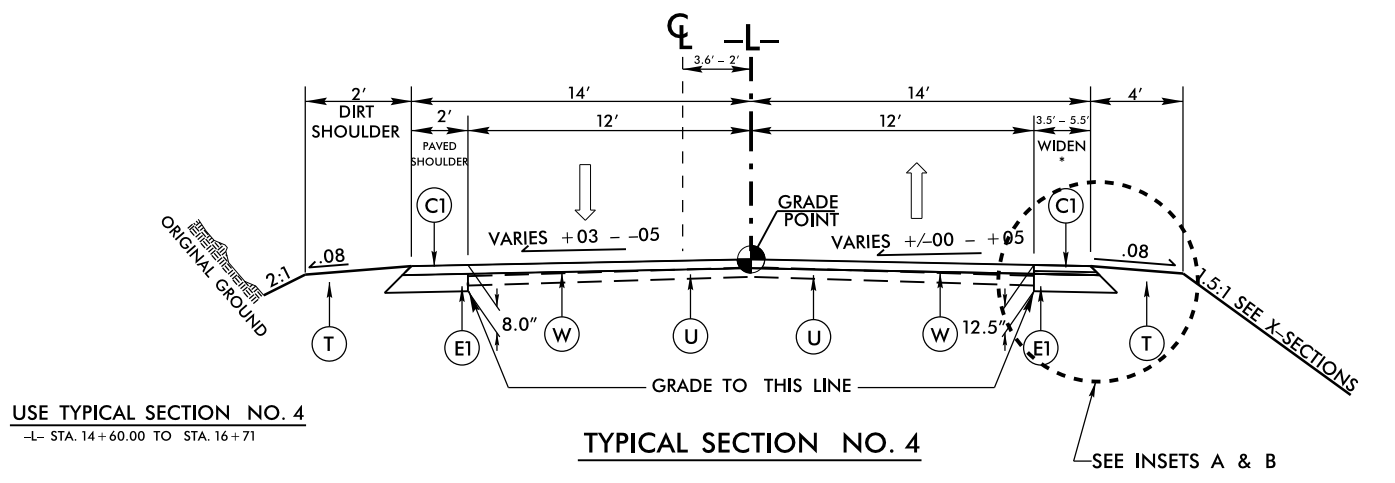
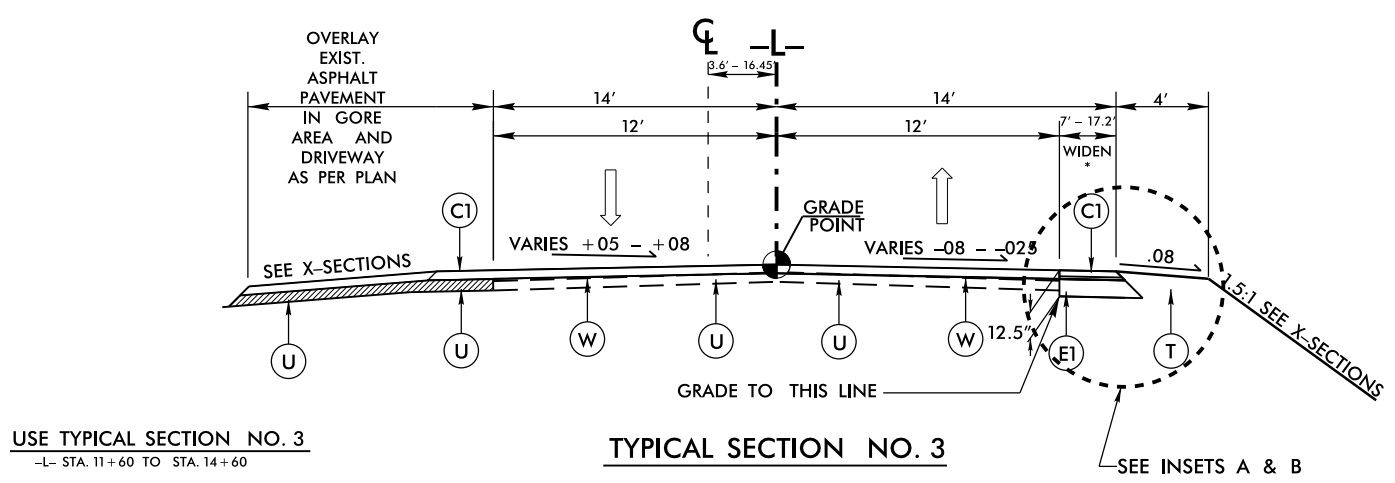
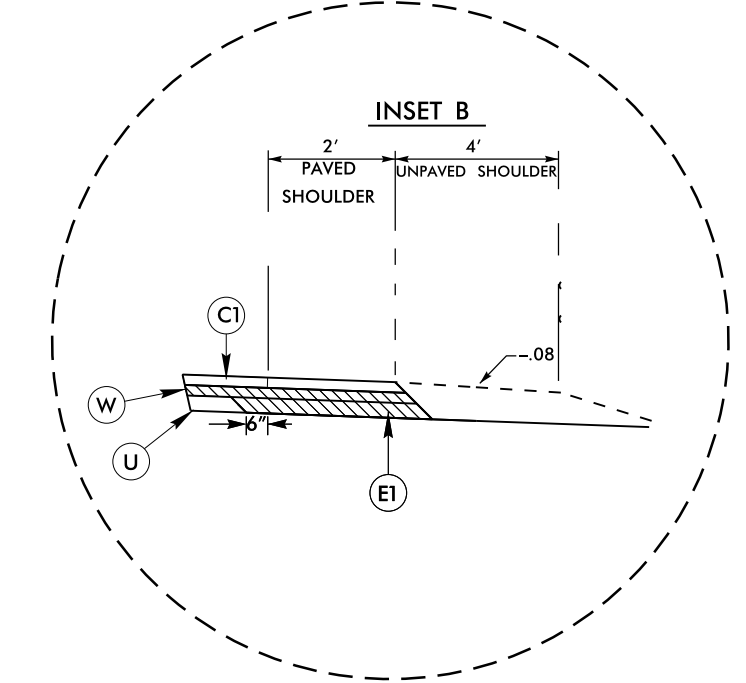
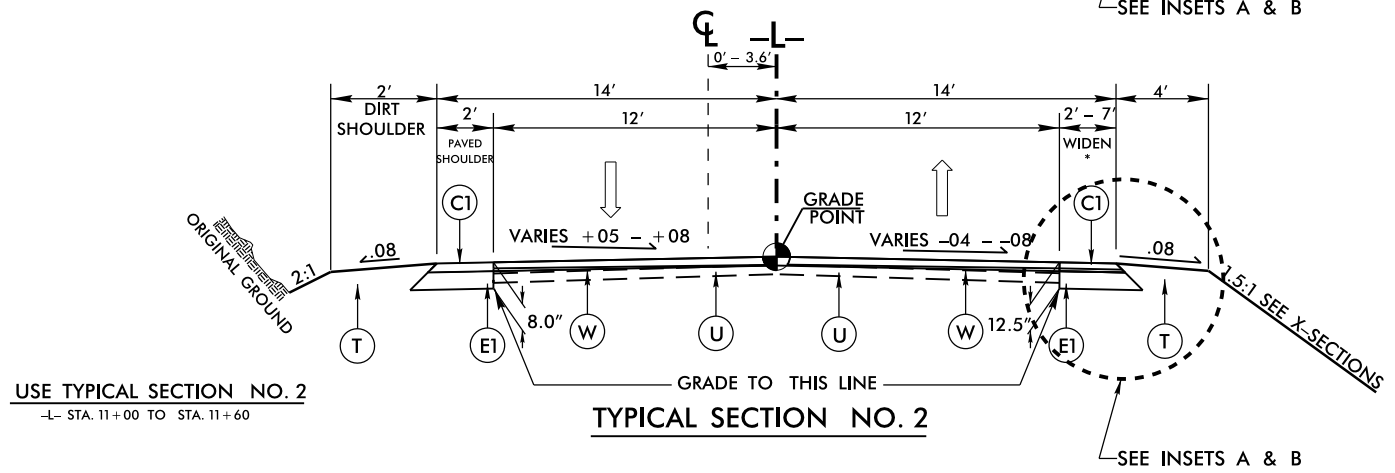
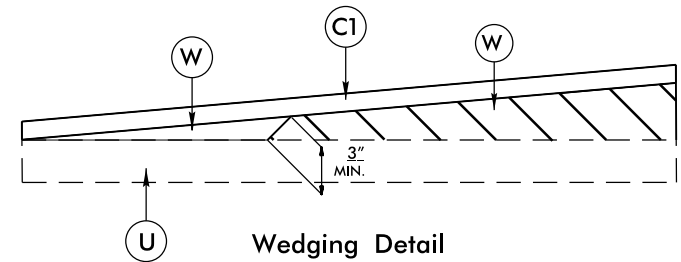
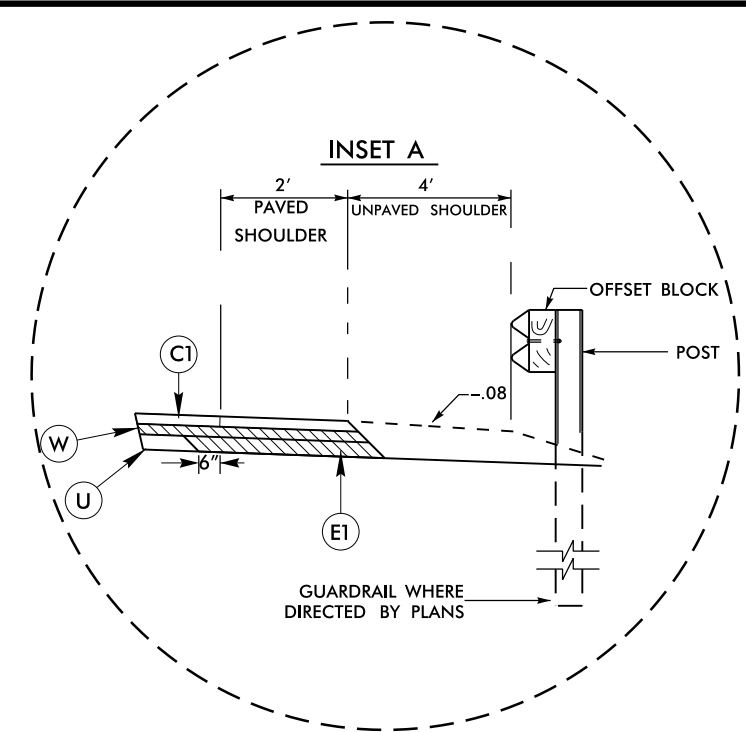
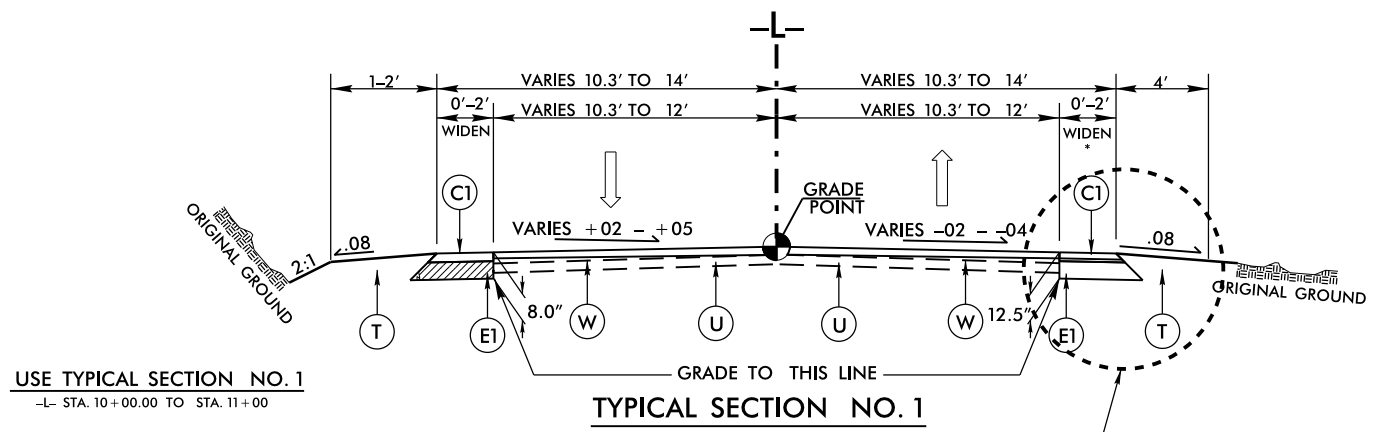

PAVEMENT SCHEDULE	
C1	PROP. 1 1/2" DEPTH ASPHALT CONCRETE SURFACE COURSE, TYPE S9.5B AT AN AVERAGE RATE OF 112 LBS. PER SQ. YD. PER 1" DEPTH. TO BE PLACED IN LAYERS NOT TO EXCEED 1 1/2" IN DEPTH.
E1	PROP. 8" DEPTH ASPHALT CONCRETE BASE COURSE, TYPE B25.0B, AT AN AVERAGE RATE OF 114 LBS. PER SQ. YD. PER 1" DEPTH. TO BE PLACED IN LAYERS NOT LESS THAN 3" IN DEPTH OR GREATER THAN 5 1/2" IN DEPTH.
W	PROP. VAR. DEPTH ASPHALT CONCRETE WEDGING COURSE, TYPE I19 AT AN AVERAGE RATE OF 114 LBS. PER SQ. FT. PER 3" DEPTH. TO BE PLACED IN LAYERS NOT TO EXCEED 3" IN DEPTH.
T	EARTH MATERIAL
U	EXISTING PAVEMENT

NOTE: ALL PAVEMENT SLOPES ARE 1:1 UNLESS SHOWN OTHERWISE.

30-JUN-2016 10:26:00
 C:\Users\atc\OneDrive\Documents\3D\dgn\practice_new_align_12-14.dgn
 3: Users atc on 06/30/2016 10:26:00

TEMPORARY STREAM DIVERSION

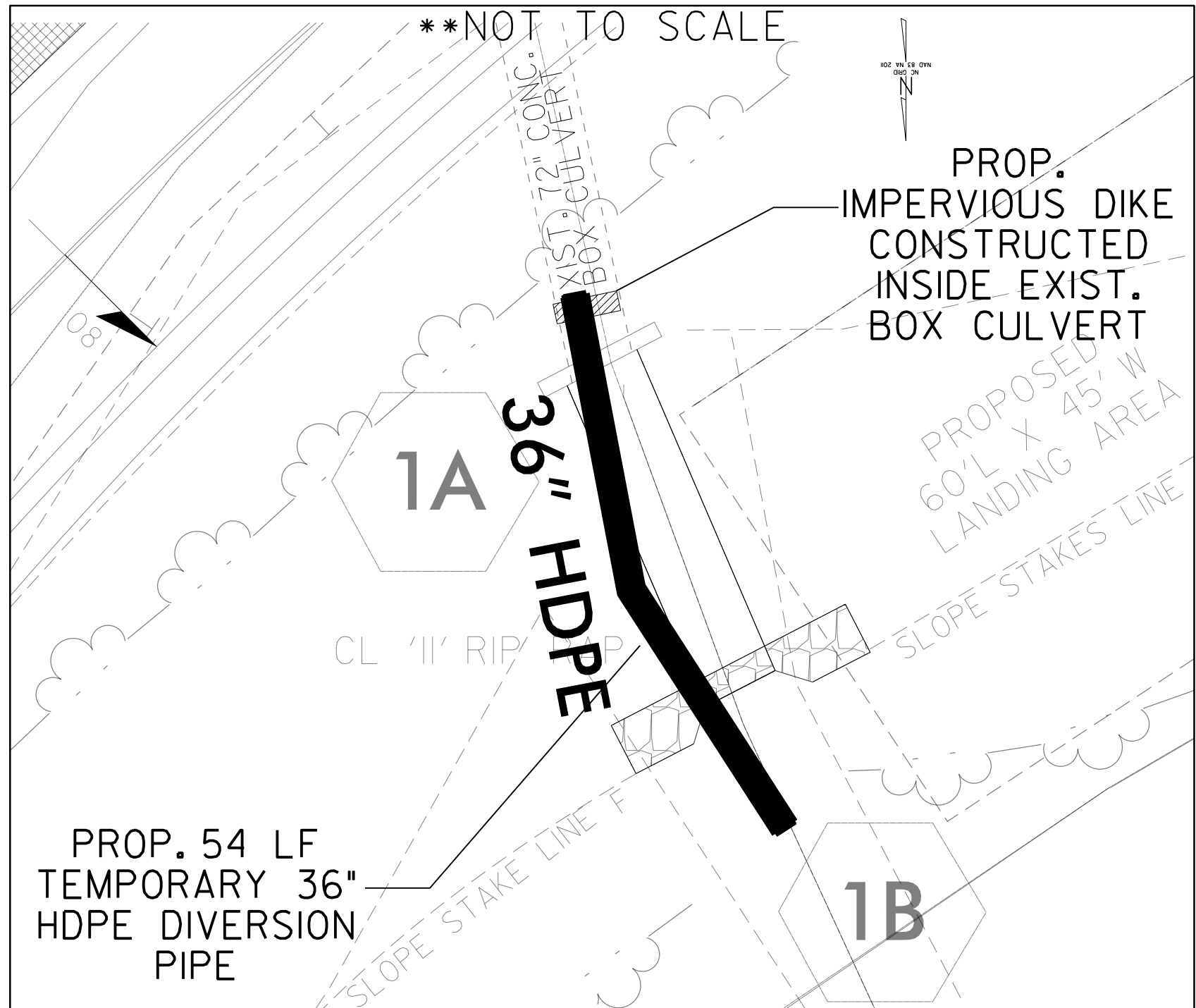
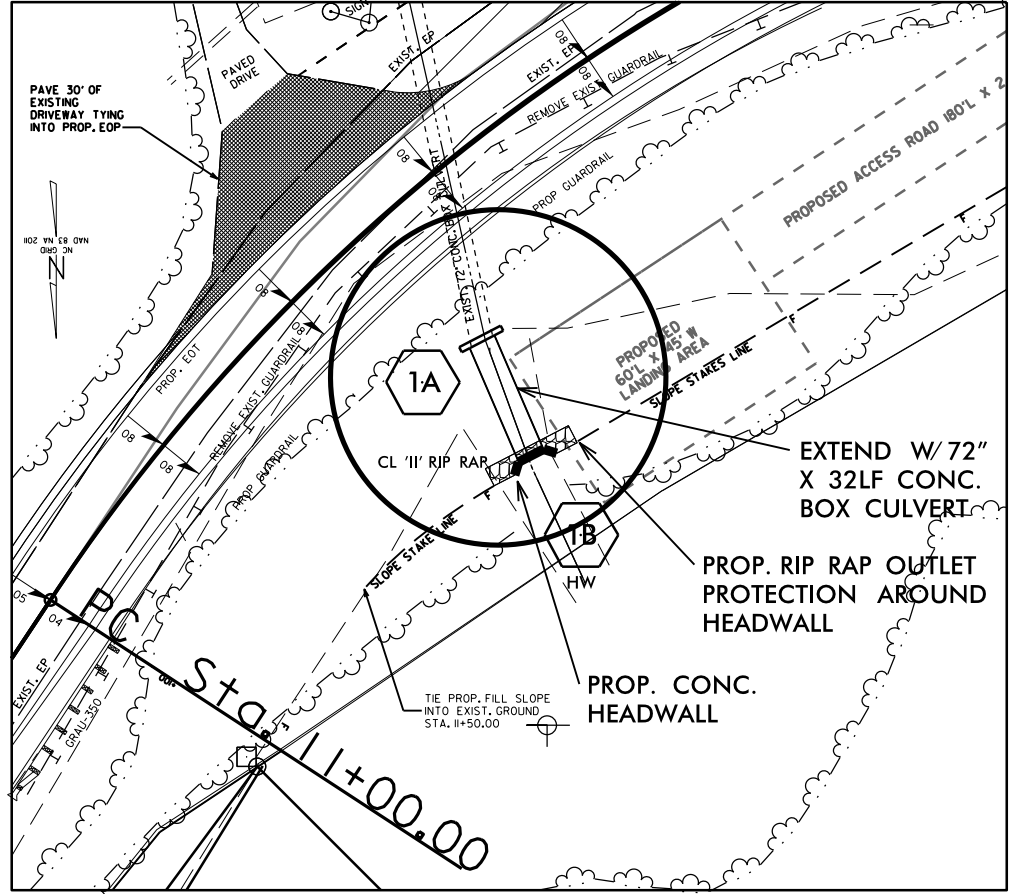

CULVERT CONSTRUCTION SEQUENCE

1. INSTALL IMPERVIOUS DIKE AND TEMPORARY 36" HDPE PIPE
2. CONSTRUCT 32' NEW 72" CONC. BOX CULVERT FLOOR
3. RELOCATE 36" TEMPORARY DIVERSION PIPE ON TOP OF NEW FLOOR
4. CONSTRUCT 32' NEW 72" CONC. BOX CULVERT WALLS
5. REMOVE IMPERVIOUS DIKE AND TEMPORARY 36" HDPE PIPE
6. CONSTRUCT 32' NEW 72" CONC. BOX CULVERT CEILING
7. CONSTRUCT NEW 72" CONC. BOX CULVERT ENDWALL AND BACKFILL

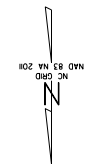

BEGIN PROJECT
-L- POT STA 10+00.00

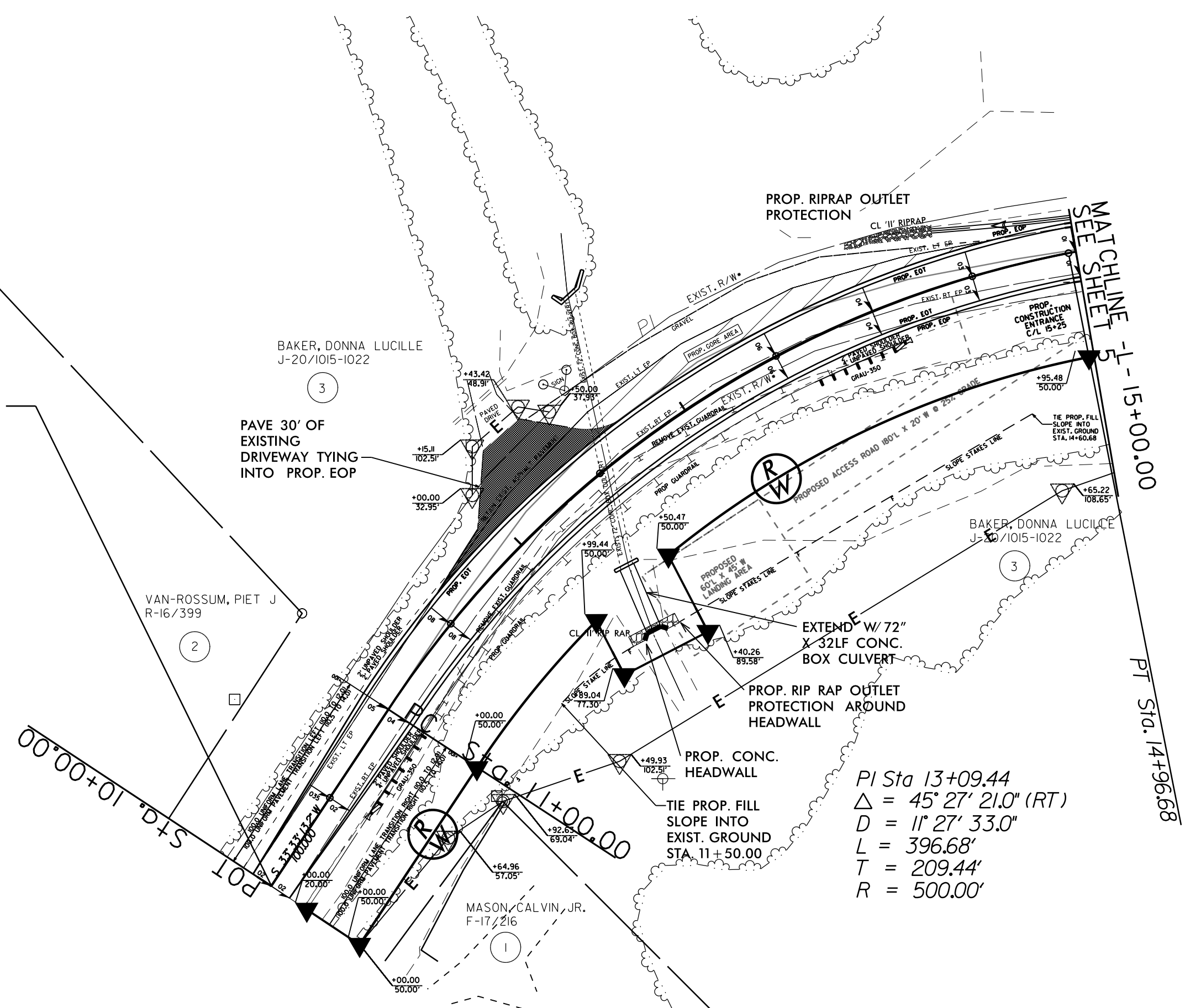

01

VAN-ROSSUM, PIET J
R-16/399

BAKER, DONNA LUCILLE
J-20/1015-1022

BAKER, DONNA LUCILLE
J-20/1015-1022

MASON, CALVIN, JR.
F-17/216

PI Sta 13+09.44
 $\Delta = 45^\circ 27' 21.0''$ (RT)
 $D = 11^\circ 27' 33.0''$
 $L = 396.68'$
 $T = 209.44'$
 $R = 500.00'$

MATCHLINE -L- SEE SHEET 5
 -L- 15+00.00
 PT Sta. 14+96.68

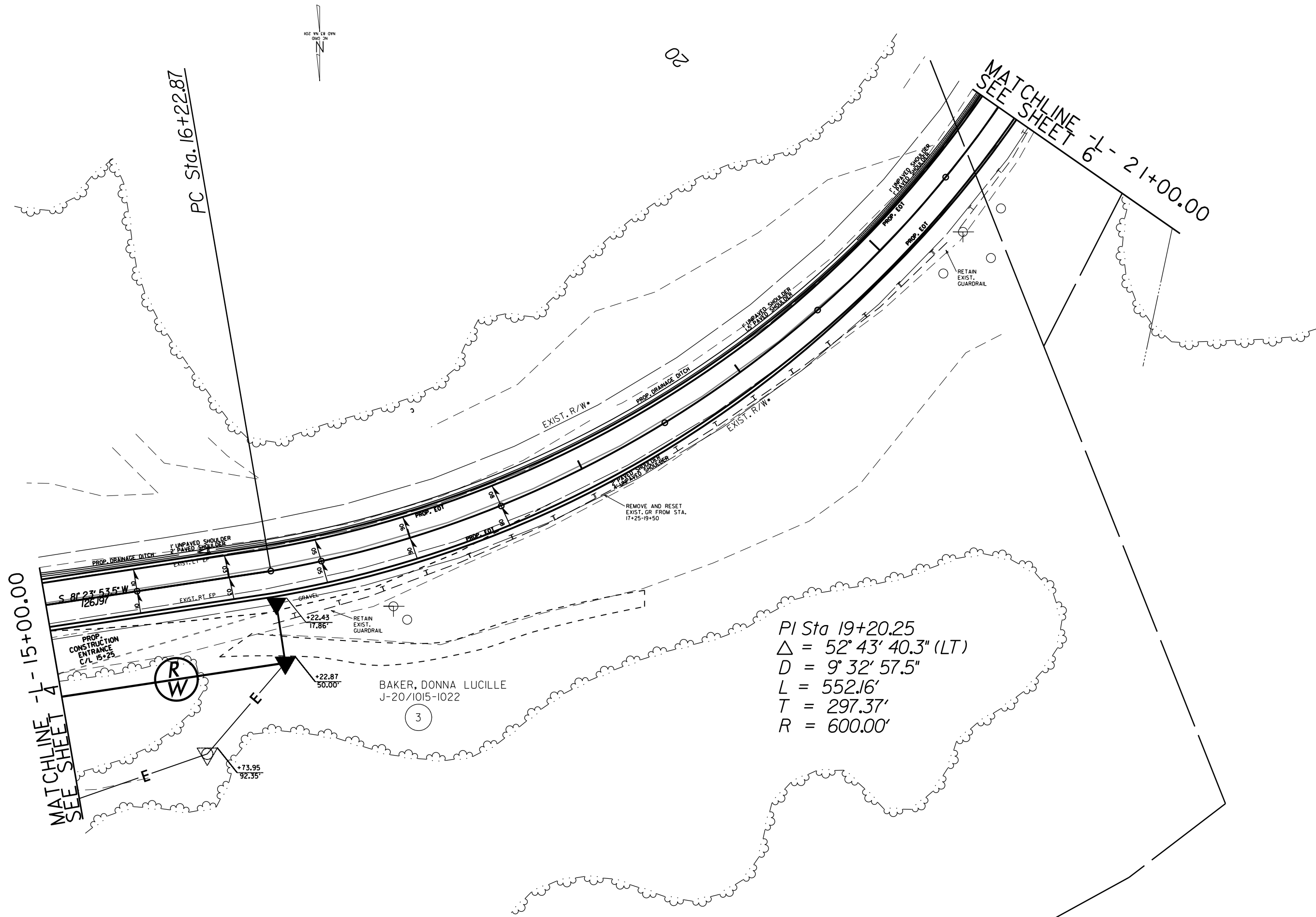

PI Sta 19+20.25
 $\Delta = 52^\circ 43' 40.3''$ (LT)
 $D = 9^\circ 32' 57.5''$
 $L = 552.16'$
 $T = 297.37'$
 $R = 600.00'$

R
W

3

BAKER, DONNA LUCILLE
J-20/1015-1022

MATCHLINE 4 - 15+00.00
SEE SHEET

MATCHLINE 6 - 21+00.00
SEE SHEET

PC Sta. 16+22.87

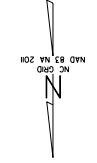

20

S 81° 23' 53.5" W
126.97

EXIST. RT EP

+22.43
17.86

RETAIN EXIST. GUARDRAIL

+22.87
50.00

+73.95
92.35

REMOVE AND RESET EXIST. GR FROM STA. 17+25-19+50

RETAIN EXIST. GUARDRAIL

EXIST. R/W

EXIST. R/W

PROP. DRAINAGE DITCH

1' UNPAVED SHOULDER
2' PAVED SHOULDER

1' UNPAVED SHOULDER
2' PAVED SHOULDER

PROP. EOT

PROP. EOT

PROP. DRAINAGE DITCH

1' UNPAVED SHOULDER
2' PAVED SHOULDER

EXIST. LT EP

EXIST. RT EP

GRAVEL

PROP. CONSTRUCTION ENTRANCE
C/L 15+25

RETAIN EXIST. GUARDRAIL

BAKER, DONNA LUCILLE
J-20/1015-1022

3

PROP. DRAINAGE DITCH

1' UNPAVED SHOULDER
2' PAVED SHOULDER

EXIST. LT EP

EXIST. RT EP

GRAVEL

PROP. CONSTRUCTION ENTRANCE
C/L 15+25

RETAIN EXIST. GUARDRAIL

BAKER, DONNA LUCILLE
J-20/1015-1022

3

PROP. DRAINAGE DITCH

1' UNPAVED SHOULDER
2' PAVED SHOULDER

EXIST. LT EP

EXIST. RT EP

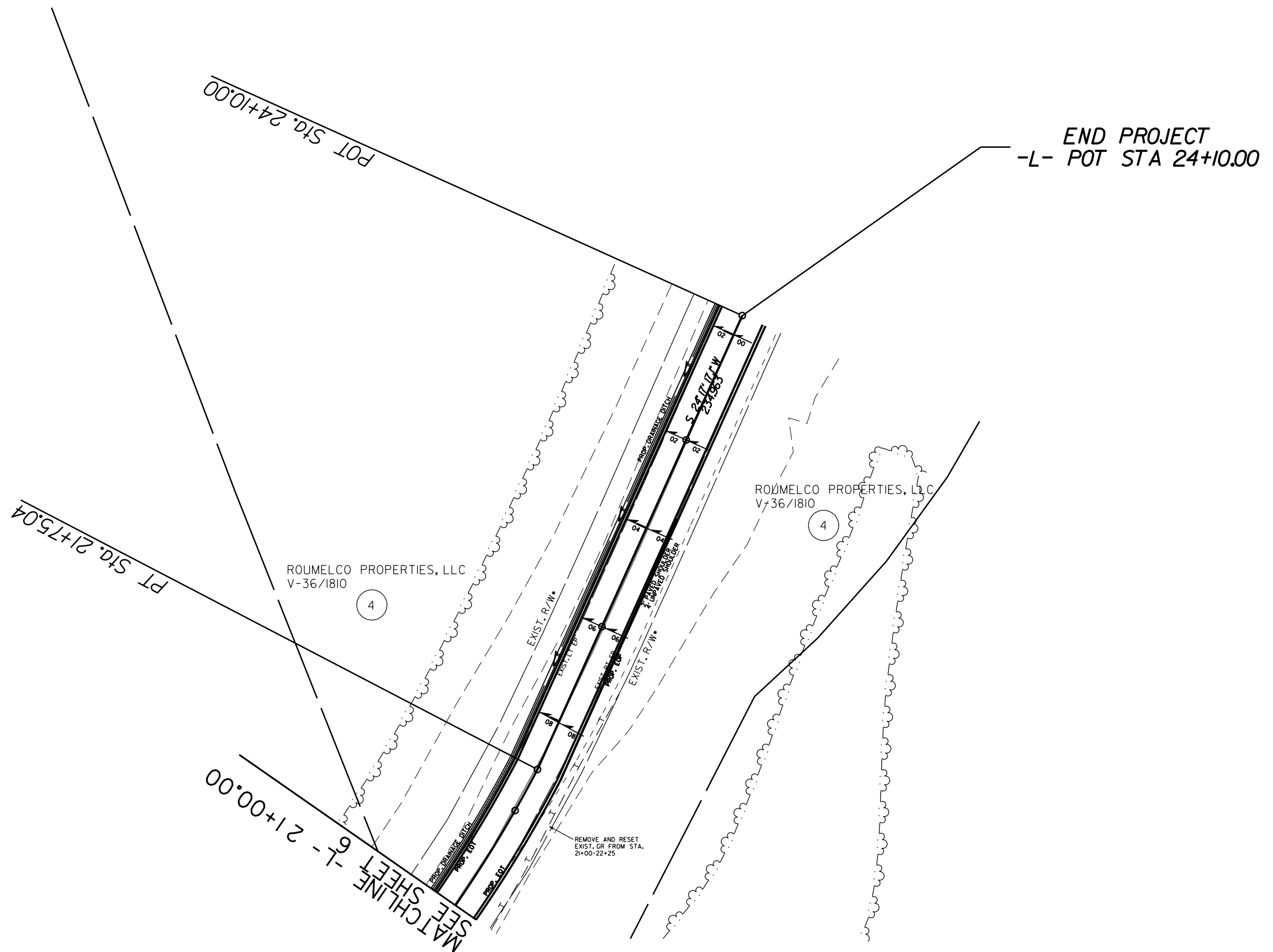

PT STA. 21+75.04

POT STA. 24+10.00

END PROJECT
-L- POT STA 24+10.00

ROUMELCO PROPERTIES, LLC
V-36/1810

ROUMELCO PROPERTIES, LLC
V-36/1810

MATCHLINE
SEE SHEET 6 -L- 21+00.00

REMOVE AND RESET
EXIST. GR FROM STA.
21+00-22+25

SURVEY CONTROL SHEET

DATUM DESCRIPTION

THE LOCALIZED COORDINATE SYSTEM DEVELOPED FOR THIS PROJECT IS BASED ON THE STATE PLANE COORDINATES ESTABLISHED BY NCDOT FOR MONUMENT "BL-1" WITH NAD 83(2011) STATE PLANE COORDINATES OF NORTHING: 579973.3240(FIT) EASTING: 598025.9210(FIT) THE AVERAGE COMBINED GRID FACTOR USED ON THIS PROJECT (GROUND TO GRID) IS: 0.99979354 THE N.C. LAMBERT GRID BEARING AND LOCALIZED HORIZONTAL GROUND DISTANCE FROM "BL-1" TO -L- STATION 10+00 IS N 35°44'20" E 361.69' ALL LINEAR DIMENSIONS ARE LOCALIZED HORIZONTAL DISTANCES VERTICAL DATUM USED IS BASED ON NCDOT MONUMENT "BL-1" (ELEV = 2535.5150') (NAVD88) GEOIDAL MODEL: G12NC

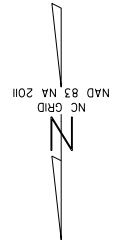

Point	North	East	Elevation
BL-1	579973.3240	598025.9210	2535.5150
BL-2	580003.5290	598132.1100	2525.0650
BL-3	579928.2260	598156.7760	2529.9000

Point	North	East	Elevation
TBM 1	580214.5230	598052.9260	2482.6600

8" SPIKE SET IN SE SIDE OF COMBO POWER/TELEPHONE/CABLE POLE +/- 1' ABOVE GROUND LOCATED 100' NORTH EAST OF EXISTING NORTH HEADWALL

Point	North	East	Elevation
TBM 2	580023.5590	598122.6520	2523.9810

8" SPIKE SET IN SW SIDE OF 24" POPLAR TREE +/- 1' ABOVE GROUND LOCATED SOUTH SIDE OF HWY. 19, 15.5' SOUTH EAST OF EXISTING ROCK SIGN

Align	Station	North	East
-L-	10+00.00	580266.058	598236.574
-L-	10+50.00	580224.389	598208.938
-L-	11+00.00	580182.721	598181.302
-L-	11+50.00	580142.428	598151.732
-L-	12+00.00	580105.288	598118.287
-L-	12+50.00	580071.673	598081.302
-L-	13+00.00	580041.918	598041.145
-L-	13+50.00	580016.321	597998.218
-L-	14+00.00	579995.137	597952.951
-L-	14+50.00	579978.578	597905.794
-L-	15+00.00	579966.944	597857.197
-L-	15+50.00	579959.466	597807.760
-L-	16+00.00	579951.987	597758.322
-L-	16+50.00	579943.377	597709.083
-L-	17+00.00	579930.682	597660.736
-L-	17+50.00	579914.008	597613.614
-L-	18+00.00	579893.469	597568.043
-L-	18+50.00	579869.208	597524.340
-L-	19+00.00	579841.393	597482.808
-L-	19+50.00	579810.218	597443.735
-L-	20+00.00	579775.899	597407.393
-L-	20+50.00	579738.674	597374.034
-L-	21+00.00	579698.801	597343.889
-L-	21+50.00	579656.558	597317.167
-L-	22+00.00	579611.852	597294.864
-L-	22+50.00	579566.277	597274.297
-L-	23+00.00	579520.703	597253.731
-L-	23+50.00	579475.128	597233.165
-L-	24+00.00	579429.554	597212.599

Type	Station	North	East
POT	10+00.00	580266.058	598236.574
PC	11+00.00	580182.7208	598181.3021
PI	13+09.44	580007.8882	598065.9807
PT	14+96.68	579967.4410	597860.4825
PC	16+22.87	579948.5661	597735.7049
PI	19+20.25	579898.2852	597442.6145
PT	21+75.04	579634.6030	597305.1306
POT	24+10.00	579420.4365	597208.4844

Align	Station	North	East	Offset RT
-L-	10+00.00	580277.1208	598219.8934	20.02
-L-	10+00.00	580293.6937	598194.9055	50.00
-L-	11+00.00	580209.8568	598139.3021	50.00
-L-	12+00.00	580140.6920	598082.7951	50.00
-L-	11+89.68	580166.2360	598069.5491	77.33
-L-	12+39.88	580146.2152	598030.9386	89.30
-L-	12+50.00	580110.4821	598049.4683	50.00
-L-	15+18.13	580013.6392	597831.5896	50.00
-L-	16+09.73	579999.9382	597741.0152	50.00
-L-	16+09.73	579968.8350	597745.7209	18.54

Align	Station	North	East	Offset RT	Offset LT
-L-	10+00.00	580293.6937	598194.9055	50.00	
-L-	10+64.65	580243.3938	598153.1453	57.00	
-L-	10+94.00	580225.8587	598127.1161	69.00	
-L-	11+50.00	580206.9536	598072.6505	102.00	
-L-	14+65.00	580079.3903	597863.6884	108.00	
-L-	15+74.00	580046.8098	597770.0615	92.00	
-L-	16+09.73	579999.9382	597741.0152	50.00	
-L-	12+00.87	580080.6134	598141.7520		34.04
-L-	12+14.92	580058.7544	598141.7520		49.85
-L-	12+40.86	580040.0093	598120.1839		49.42
-L-	12+50.22	580042.4724	598104.8801		37.73

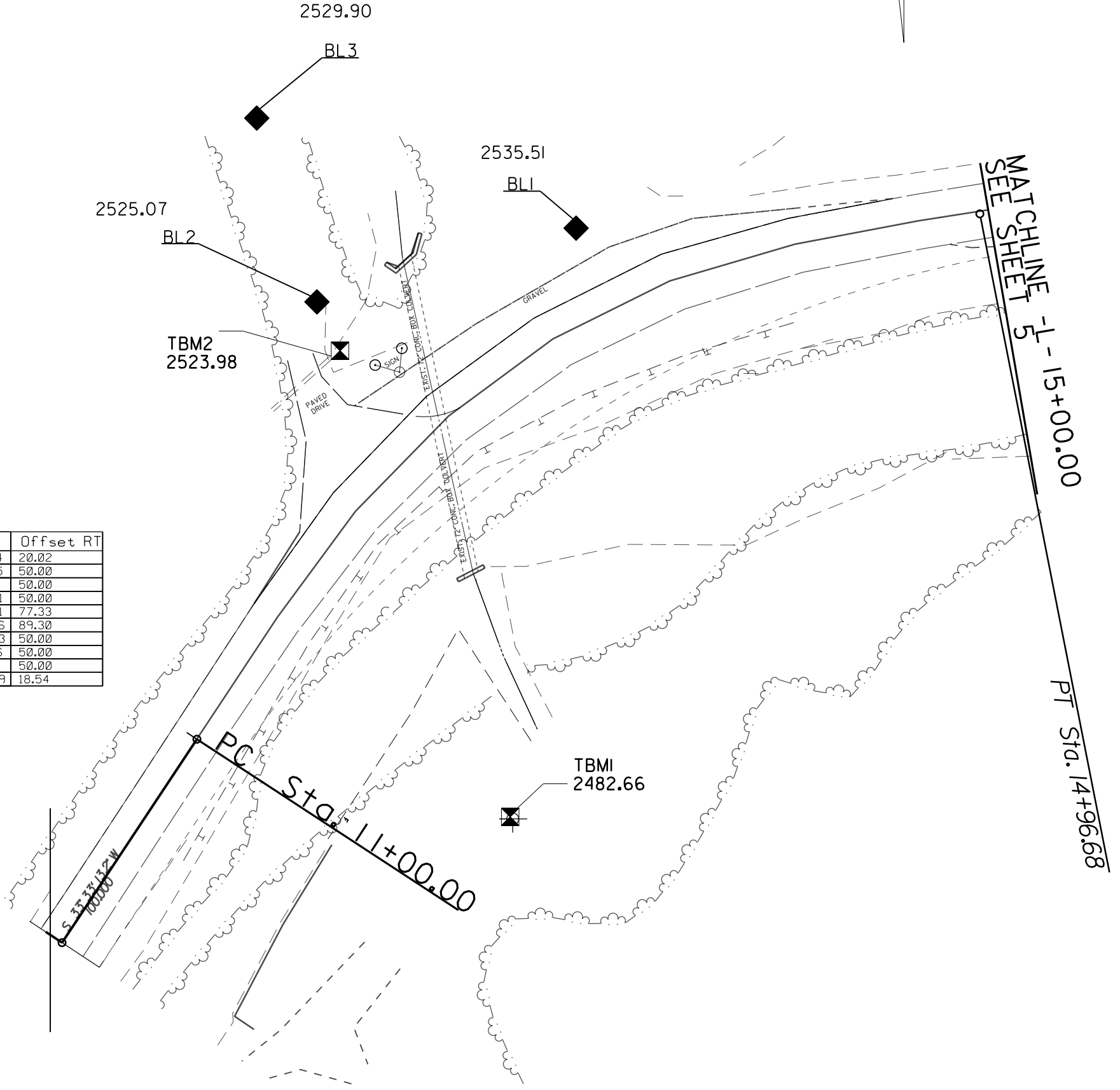

5/14/99
30-JUN-2016 08:47
C:\Users\vincorri\OneDrive\desktop\top\topom alignment practice\3D\dgn\for_structures2\dgn\prof\DN00378_sheet1_Rdy.plt.dgn

2610
2600
2590
2580
2570
2560
2550
2540
2530
2520
2510
2500
2490
2480
2470
2460
2450
2440
2430
2420
10+00 11+00 12+00

2,507.92

PI = 11+00.00
EL = 2,515.80'

(+)7.8800%

(+)8.1703%

2580
2570
2560
2550
2540
2530
2520
2510
2500
2490
2480
2470
2460
2450
2440
2430
2420

5/14/99
28-JUN-2016 09:12
C:\Users\vincorri\OneDrive\Documents\3D\topom alignment practice\3D\dgn\for_structures2\dgn\prof\DN00378_sheets4_Rdu_pf1.dgn

2680
2670
2660
2650
2640
2630
2620
2610
2600
2590
2580
2570
2560
2550
2540
2530
2520
2510
2500
2490

18+00

19+00

20+00

2650
2640
2630
2620
2610
2600
2590
2580
2570
2560
2550
2540
2530
2520
2510
2500
2490

(+)8.4754%

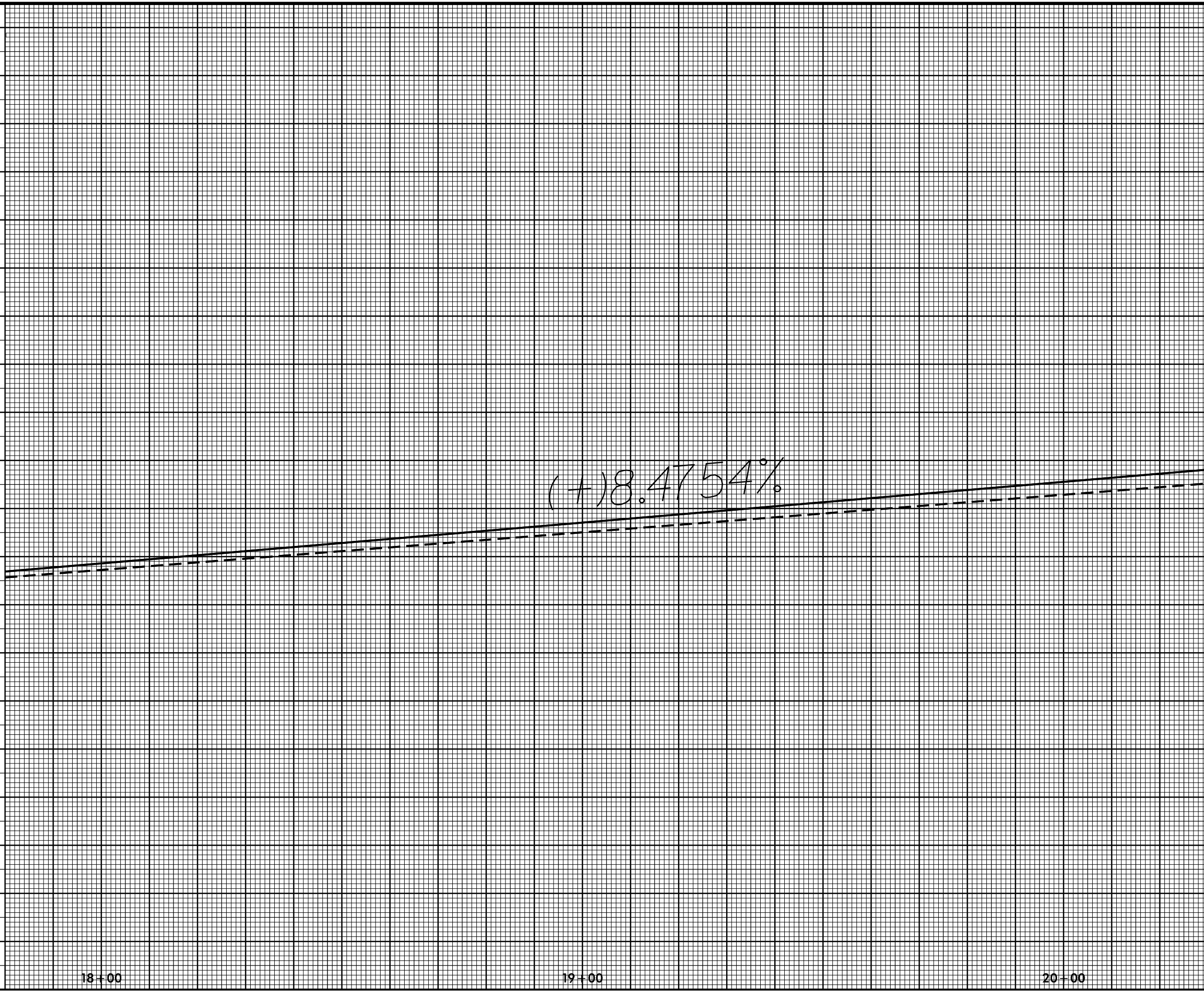

5/14/99
28-JUN-2016 0:15
C:\Users\vincorri\OneDrive\Documents\practice\3D\dgn\for_structures2\dgn\prof\DN00378_sheets5_Rdu_pf1.dgn

2700
2690
2680
2670
2660
2650
2640
2630
2620
2610
2600
2590
2580
2570
2560
2550
2540
2530
2520
2510

2670
2660
2650
2640
2630
2620
2610
2600
2590
2580
2570
2560
2550
2540
2530
2520
2510

21+00

22+00

23+00

PI = 21+75.04
EL = 2,605.38'
VC = 150'

(+)8.4757% (+)6.0233%

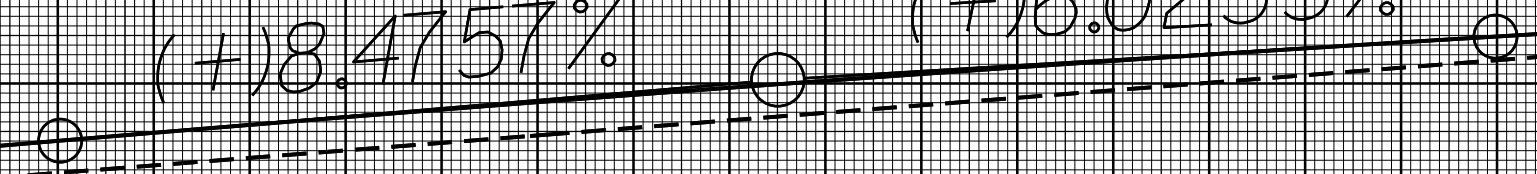

STATE OF NORTH CAROLINA
DIVISION OF HIGHWAYS

PAVEMENT MARKING PLAN

MACON COUNTY

LOCATION: ALONG NC HWY 19 /74 NEAR MACON/CHEROKEE COUNTY LINE

TYPE OF WORK: GRADING, PAVING, BOX CULVERT INSTALLATION, GUARDRAIL INSTALLATION

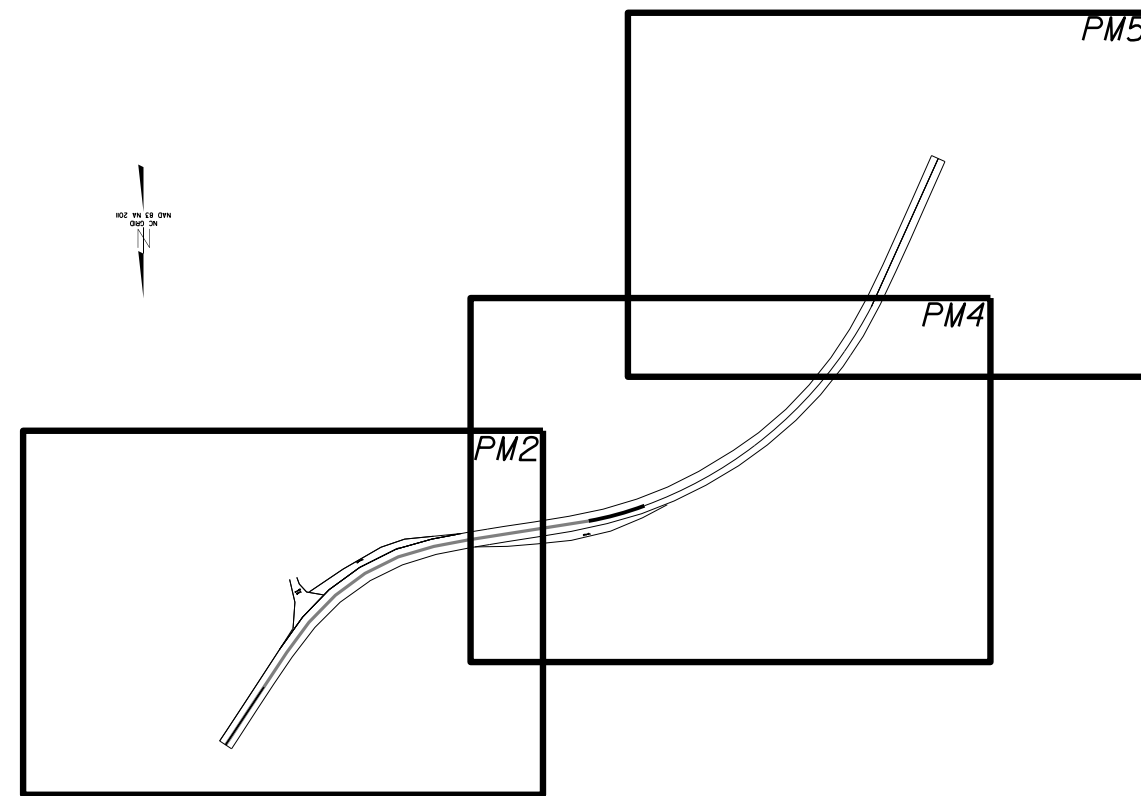

29-NOV-2016 09:36 S:\Dis+3\Macon\DN00547 (DN00534)\DN00378) topfonrealign\dgm\pavement marking\DN00547_pvmntmkg_Rdy_dsn.dgn orbrown4 AT D14CAD272166

CONTRACT: DN00547 TIP: SS-4914BO WBS ELEMENT:43936.3.1;2016PT.14.03.10561.1

ROADWAY STANDARD DRAWINGS

2012 ROADWAY STANDARD DRAWINGS
 The following Roadway Standards as appear in "Roadway Standard Drawings" - Highway Design Branch - N.C. Department of Transportation - Raleigh, N.C., dated January 17, 2012 and the latest revision thereto are applicable to this project and by reference hereby are considered a part of these plans.

STD. NO.	TITLE
I205.01	Pavement Markings- Line Types and Offsets
I205.02	Pavement Markings- 2 Lane and Multi-lane Roadways

INDEX

PM-1	PAVEMENT MARKING PLAN TITLE SHEET
PM2-PM4	PAVEMENT MARKING DETAIL

PAVEMENT MARKING SCHEDULE

FINAL PAVEMENT MARKINGS		
CLI	YELLOW DOUBLE CENTER	4" THERMO (50 MIL)
ETI	WHITE EDGELINE	4" THERMO (50 MIL)
CWG	WHITE GORE LINE	8" THERMO (50 MIL)

GENERAL NOTES

THE FOLLOWING GENERAL NOTES APPLY AT ALL TIMES FOR THE DURATION OF THE CONSTRUCTION PROJECT EXCEPT WHEN OTHERWISE NOTED IN THE PLAN OR AS DIRECTED BY THE ENGINEER.

A) INSTALL PAVEMENT MARKINGS ON THE FINAL SURFACE AS FOLLOWS:	ROAD NAME	MARKING	MARKER
	HWY 19 / 74	THERMOPLASTIC	N/A

- PLACE ONE (1) APPLICATION OF THERMOPLASTIC PAVEMENT MARKINGS ON THE FINAL WEARING SURFACE.
- A) TIE PROPOSED PAVEMENT MARKING LINES TO EXISTING PAVEMENT MARKING LINES
- B) REMOVE/REPLACE ANY CONFLICTING/DAMAGED PAVEMENT MARKINGS AND MARKERS.



BEGIN PROJECT
-L- POT STA 10+00.00

0/

POT Sta. 10+00.00

FC Sta. 11+00.00

MATCHLINE -L- 15+00.00
SEE SHEET PM3

PT Sta. 14+96.68

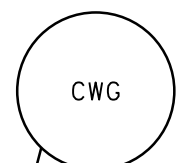
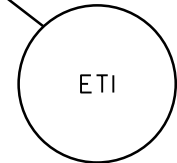
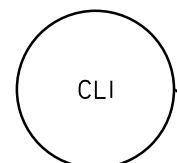
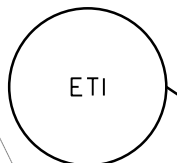

GORE AREA ON
RETAINED EXIST.
PAVEMENT

PAVED
DRIVE

RETAIN EXIST. ASPHALT PAVEMENT

GRAVEL

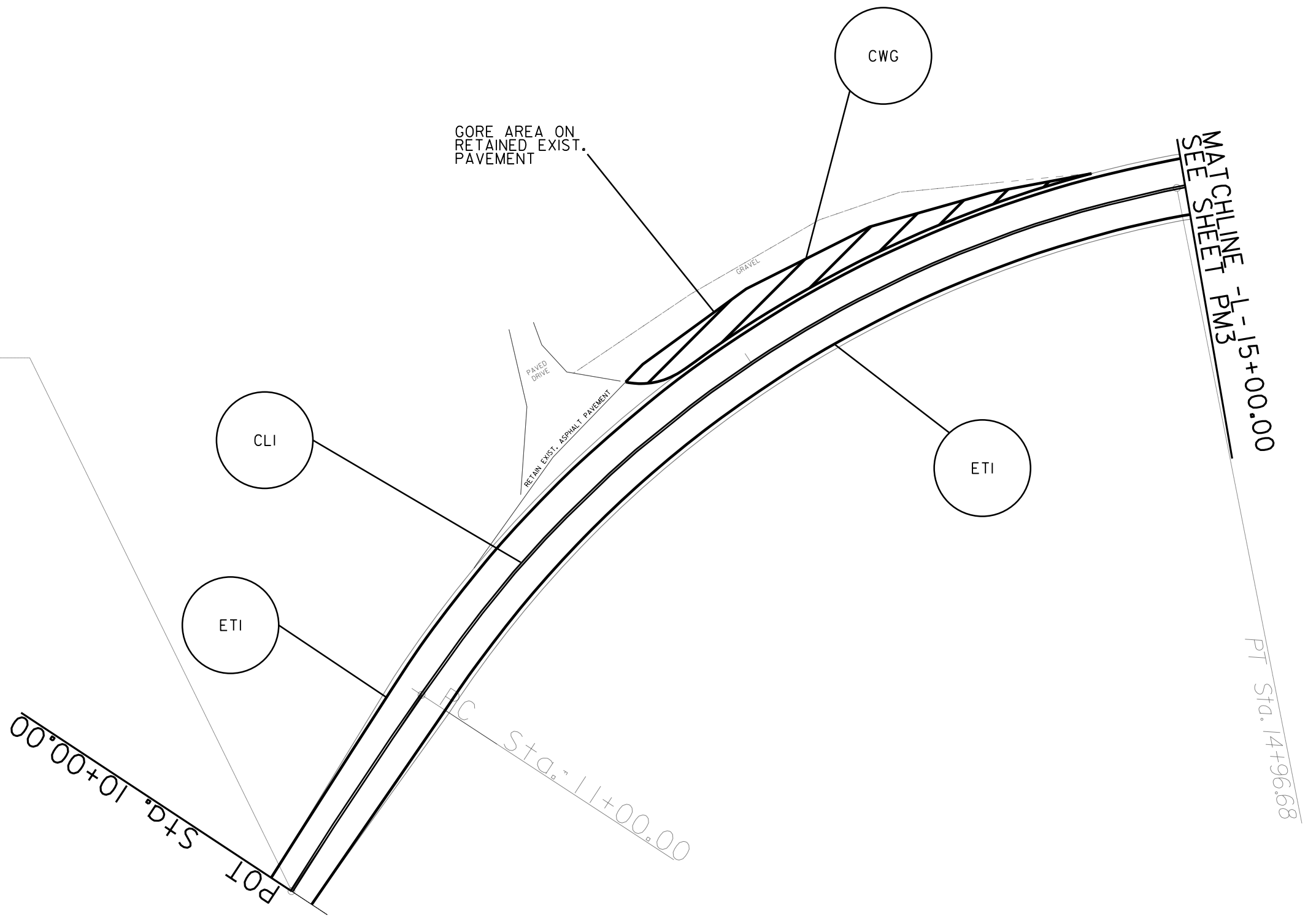



20

PC Sta. 16+22.87

MATCHLINE -L- 15+00.00
SEE SHEET PM2

MATCHLINE -L- 21+00.00
SEE SHEET PM4

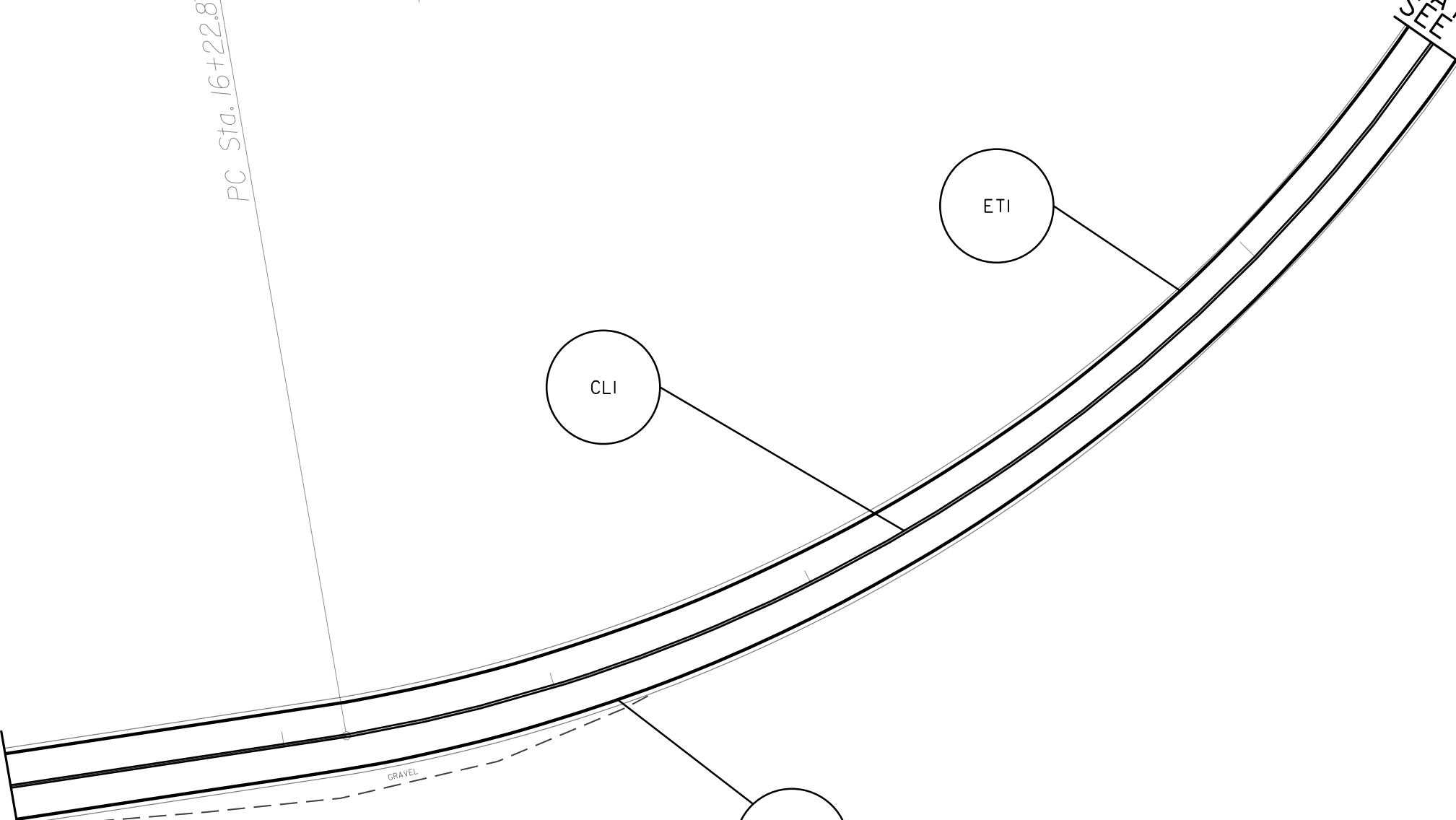

CLI

ETI

ETI

GRAVEL

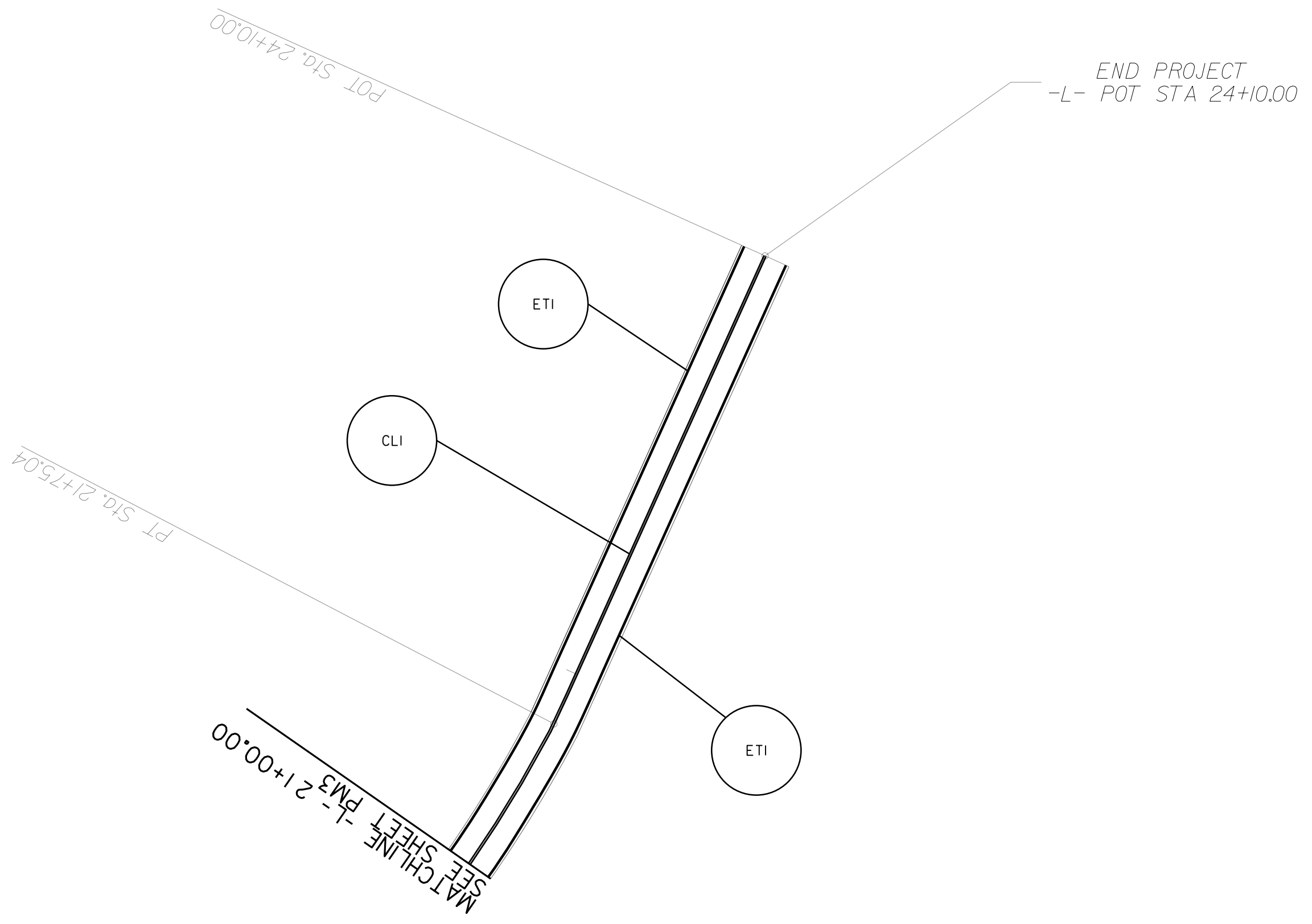

STATE OF NORTH CAROLINA
 DIVISION OF HIGHWAYS

 PLAN FOR PROPOSED
 HIGHWAY EROSION CONTROL

MACON COUNTY

LOCATION: ALONG NC HWY 19 /74 NEAR MACONCHEROKEE COUNTY LINE
 TYPE OF WORK: GRADING, PAVING, BOX CULVERT INSTALLATION, GUARDRAIL INSTALLATION

STATE	STATE PROJECT REFERENCE NO.	SHEET NO.	TOTAL SHEETS
N.C.	43936.3.1 & 2016CPT.14.03.10561.1	EC-1	
STATE PROJ. NO.	F.A. PROJ. NO.	DESCRIPTION	

EROSION AND SEDIMENT CONTROL MEASURES

Std. #	Description	Symbol
1630.03	Temporary Silt Ditch	---
1630.05	Temporary Diversion	---
1605.01	Temporary Silt Fence	--- --- --- ---
1606.01	Special Sediment Control Fence	--- --- --- ---
1622.01	Temporary Berms and Slope Drains	--- --- --- ---
1630.02	Silt Basin Type B	--- --- --- ---
1633.01	Temporary Rock Silt Check Type-A	--- --- --- ---
	Temporary Rock Silt Check Type-A with Matting and Polyacrylamide (PAM)	--- --- --- ---
1633.02	Temporary Rock Silt Check Type-B	--- --- --- ---
	Wattle / Coir Fiber Wattle	--- --- --- ---
	Wattle / Coir Fiber Wattle with Polyacrylamide (PAM)	--- --- --- ---
1634.01	Temporary Rock Sediment Dam Type-A	--- --- --- ---
1634.02	Temporary Rock Sediment Dam Type-B	--- --- --- ---
1635.01	Rock Pipe Inlet Sediment Trap Type-A	--- --- --- ---
1635.02	Rock Pipe Inlet Sediment Trap Type-B	--- --- --- ---
1630.04	Stilling Basin	--- --- --- ---
1630.06	Special Stilling Basin	--- --- --- ---
	Rock Inlet Sediment Trap:	--- --- --- ---
1632.01	Type A	--- --- --- ---
1632.02	Type B	--- --- --- ---
1632.03	Type C	--- --- --- ---
	Skimmer Basin	--- --- --- ---
	Tiered Skimmer Basin	--- --- --- ---
	Infiltration Basin	--- --- --- ---

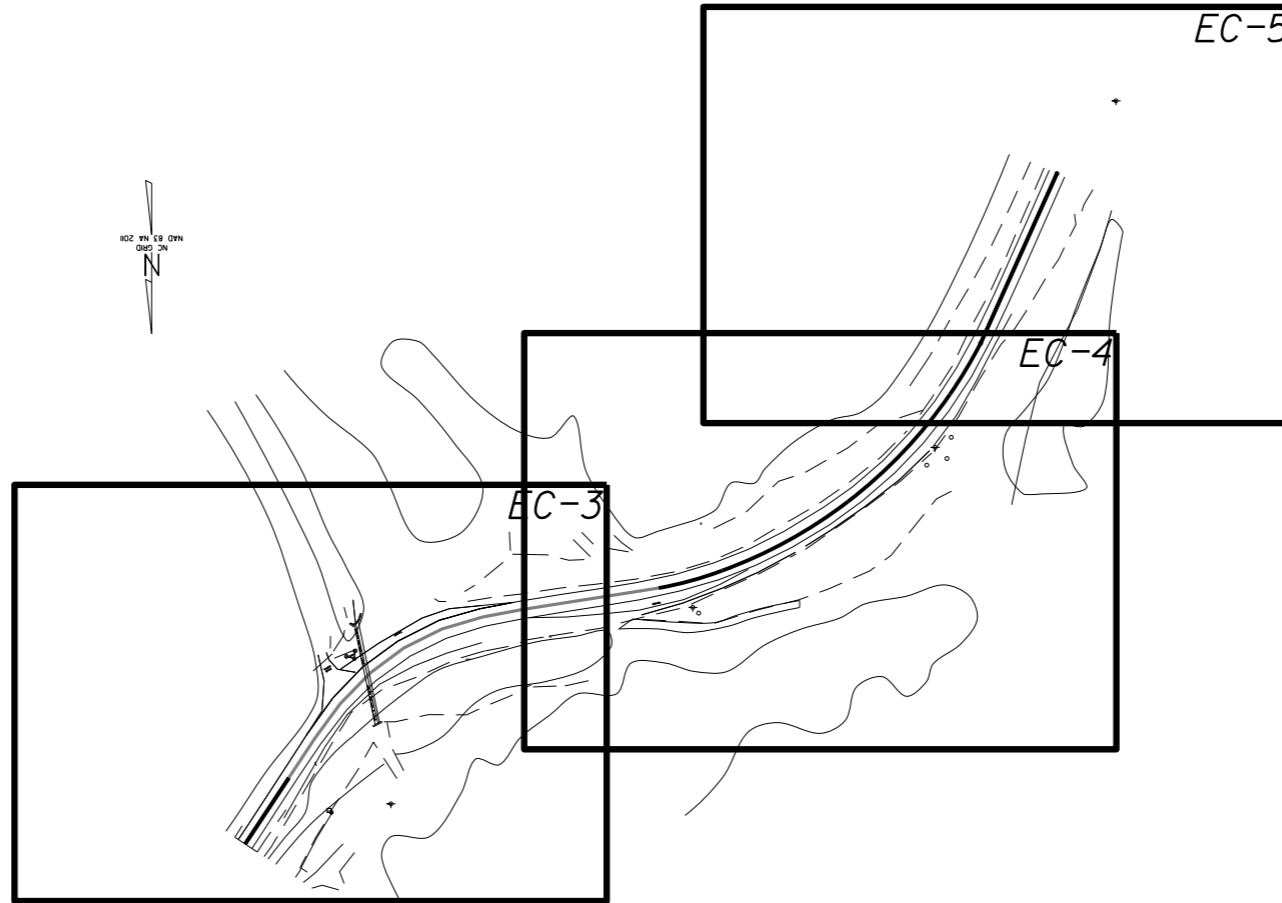

CONTRACT: DN00547 TIP: SS-4914BO WBS ELEMENT: 43936.3.1;2016CPT.14.03.10561.1

GRAPHIC SCALE

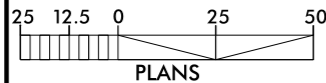

DIVISION 14, DISTRICT 3
 DIVISION OF HIGHWAYS
 STATE OF NORTH CAROLINA

THESE EROSION AND SEDIMENT CONTROL PLANS COMPLY WITH THE REGULATIONS SET FORTH BY THE NCG-010000 GENERAL CONSTRUCTION PERMIT EFFECTIVE AUGUST 3, 2011 ISSUED BY THE NORTH CAROLINA DEPARTMENT OF ENVIRONMENT AND NATURAL RESOURCES DIVISION OF WATER QUALITY.

Prepared in the Office of:
DIVISION 14, DISTRICT 3
 191 ROBBINSVILLE ROAD
 ANDREWS, NC 28901
 2012 STANDARD SPECIFICATIONS

Roadway Standard Drawings

The following roadway english standards as appear in "Roadway Standard Drawings"- Roadway Design Unit - N. C. Department of Transportation - Raleigh, N. C., dated January 2012 and the latest revision thereto are applicable to this project and by reference hereby are considered a part of these plans.

1604.01 Railroad Erosion Control Detail	1632.01 Rock Inlet Sediment Trap Type A
1605.01 Temporary Silt Fence	1632.02 Rock Inlet Sediment Trap Type J
1606.01 Special Sediment Control Fence	1632.03 Rock Inlet Sediment Trap Type C
1607.01 Gravel Construction Entrance	1633.01 Temporary Rock Silt Check Type A
1622.01 Temporary Berms and Slope Drains	1633.02 Temporary Rock Silt Check Type J
1630.01 Riser Basin	1634.01 Temporary Rock Sediment Dam Type A
1630.02 Silt Basin Type J	1634.02 Temporary Rock Sediment Dam Type J
1630.03 Temporary Silt Ditch	1635.01 Rock Pipe Inlet Sediment Trap Type A
1630.04 Stilling Basin	1635.02 Rock Pipe Inlet Sediment Trap Type J
1630.05 Temporary Diversion	1640.01 Coir Fiber Jaffle
1630.06 Special Stilling Basin	1645.01 Temporary Stream Crossing
1631.01 Matting Installation	

DIVISION OF HIGHWAYS
STATE OF NORTH CAROLINA

SOIL STABILIZATION TIMEFRAMES

<i>SITE DESCRIPTION</i>	<i>STABILIZATION TIME</i>	<i>TIMEFRAME EXCEPTIONS</i>
PERIMETER DIKES, SWALES, DITCHES AND SLOPES	7 DAYS	NONE
HIGH QUALITY WATER (HQW) ZONES	7 DAYS	NONE
SLOPES STEEPER THAN 3:1	7 DAYS	IF SLOPES ARE 10' OR LESS IN LENGTH AND ARE NOT STEEPER THAN 2:1, 14 DAYS ARE ALLOWED.
SLOPES 3:1 OR FLATTER	14 DAYS	7 DAYS FOR SLOPES GREATER THAN 50' IN LENGTH.
ALL OTHER AREAS WITH SLOPES FLATTER THAN 4:1	14 DAYS	NONE, EXCEPT FOR PERIMETERS AND HQW ZONES.

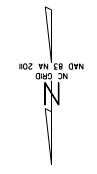

BEGIN PROJECT
-L- POT STA 10+00.00

POT STA. 10+00.00

**INSTALL MATTING FOR
EROSION CONTROL IN THE
PROPOSED DITCH LINE.**

**Place Matting for Erosion Control
on Slope as Work Allows.
Sta. 10+50 to Sta. 15+50 RT**

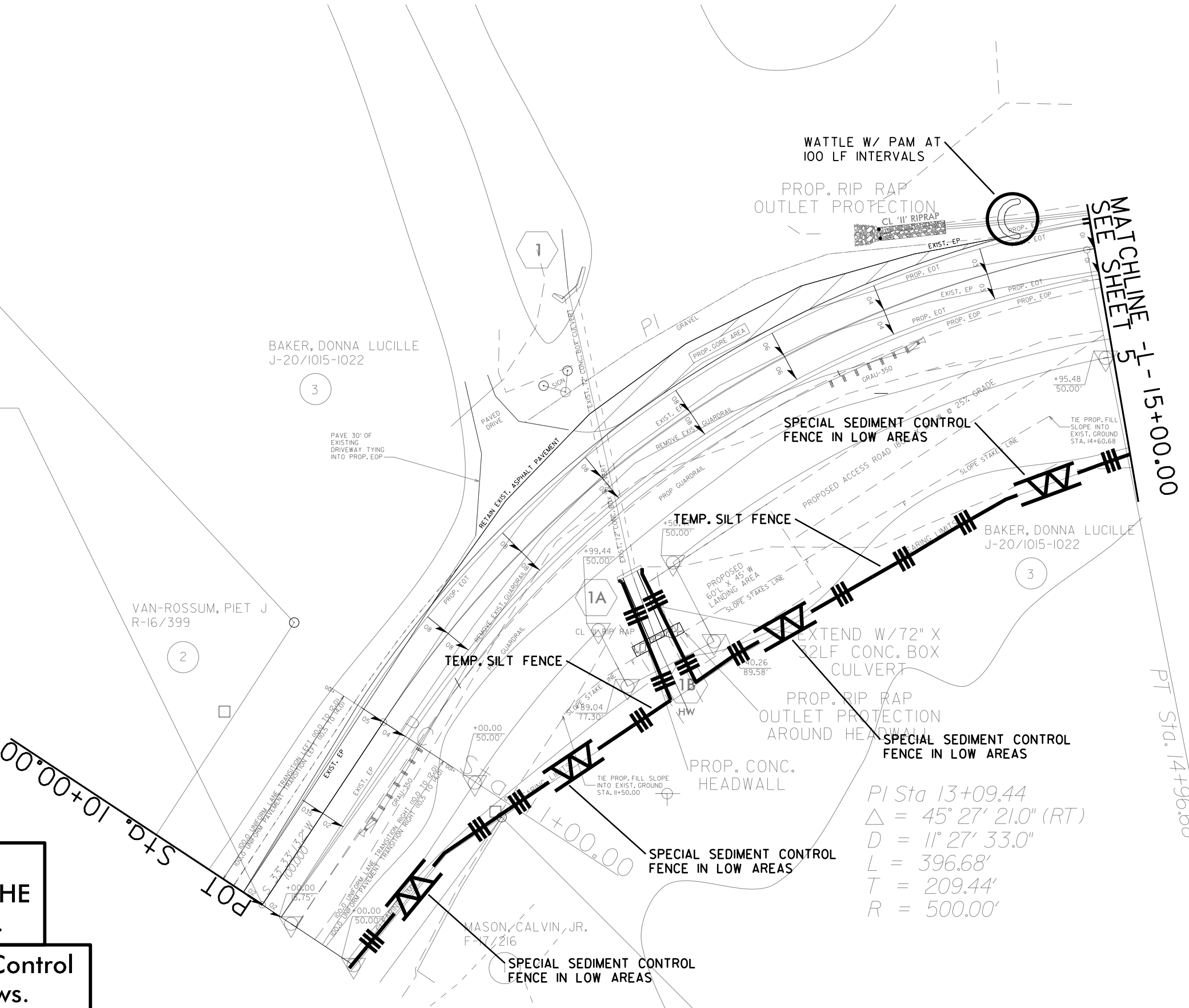

$Pi Sta 13+09.44$
 $\Delta = 45^\circ 27' 21.0'' (RT)$
 $D = 11^\circ 27' 33.0''$
 $L = 396.68'$
 $T = 209.44'$
 $R = 500.00'$

MATCHLINE -L- 15+00.00
SEE SHEET 5

PT Sta. 14+96.68

STATE OF
NORTH CAROLINA
DEPT. OF TRANSPORTATION
DIVISION OF HIGHWAYS
RALEIGH, N.C.

STATE OF
NORTH CAROLINA
DEPT. OF TRANSPORTATION
DIVISION OF HIGHWAYS
RALEIGH, N.C.

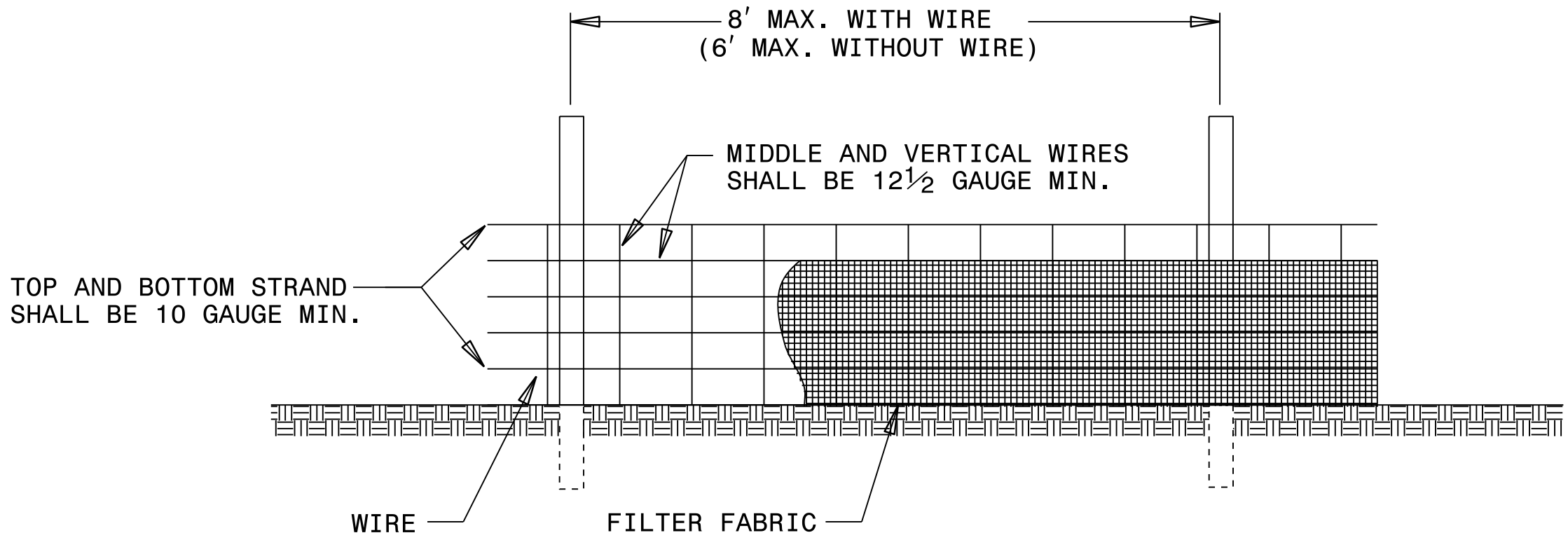

NOTES

USE WIRE A MINIMUM OF 32" IN WIDTH AND WITH A MINIMUM OF 6 LINE WIRES WITH 12" STAY SPACING.

USE FILTER FABRIC A MINIMUM OF 36" IN WIDTH AND FASTEN ADEQUATELY TO THE WIRE AS DIRECTED BY THE ENGINEER.

PROVIDE 5'-0" STEEL POST OF THE SELF-FASTENER ANGLE STEEL TYPE.

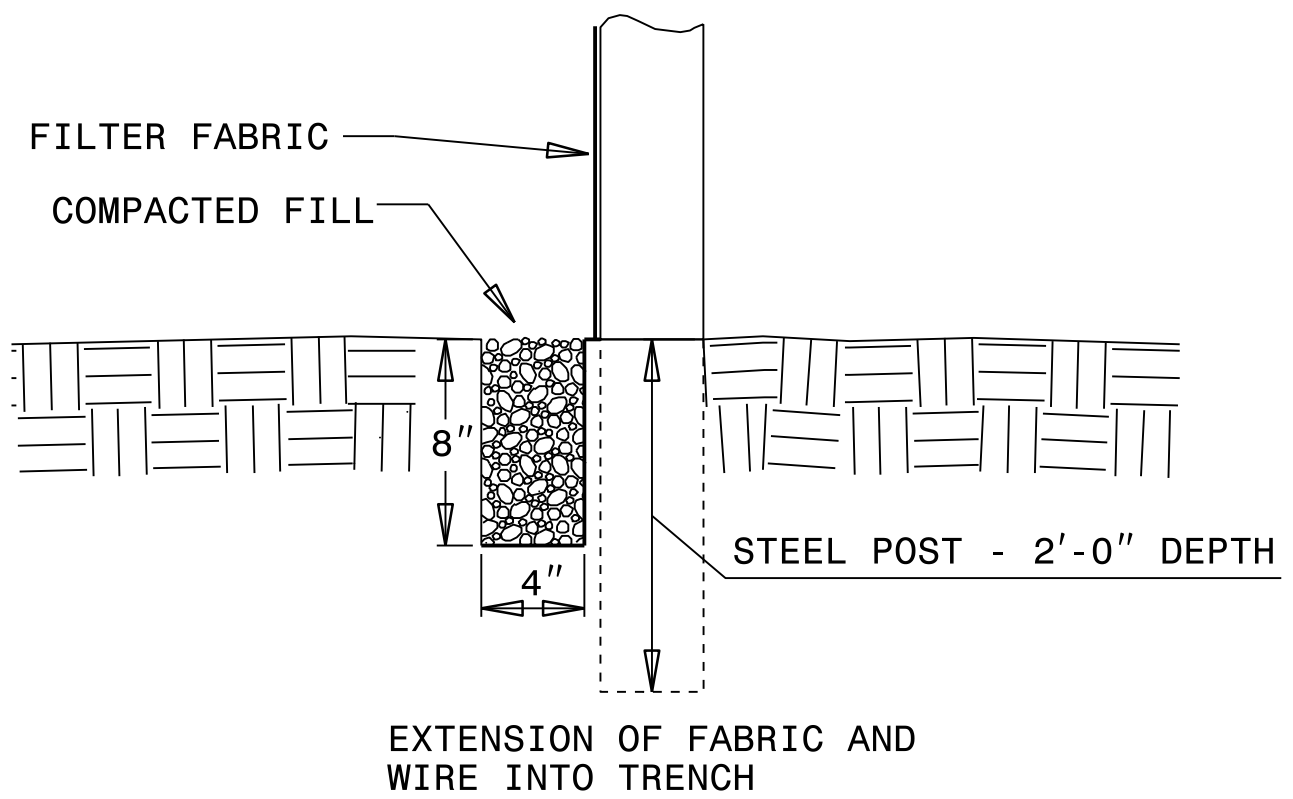

ENGLISH STANDARD DRAWING FOR
TEMPORARY SILT FENCE

ENGLISH STANDARD DRAWING FOR
TEMPORARY SILT FENCE

WATTLE WITH POLYACRYLAMIDE (PAM) DETAIL

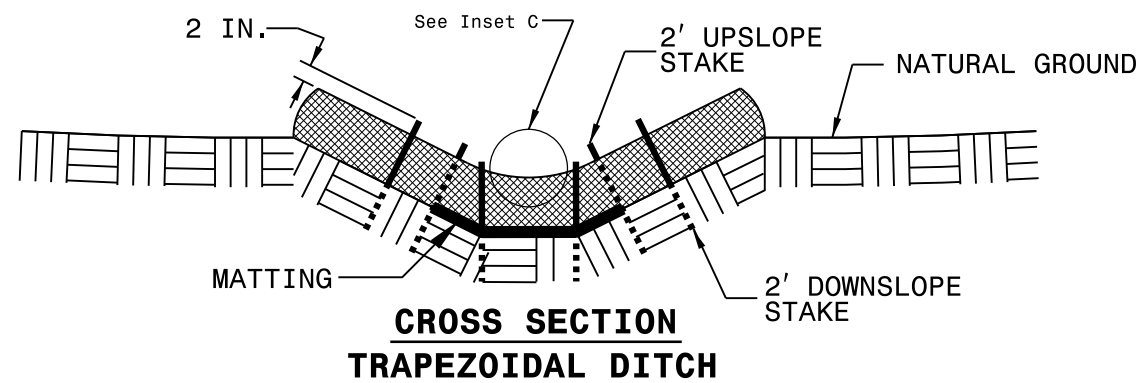
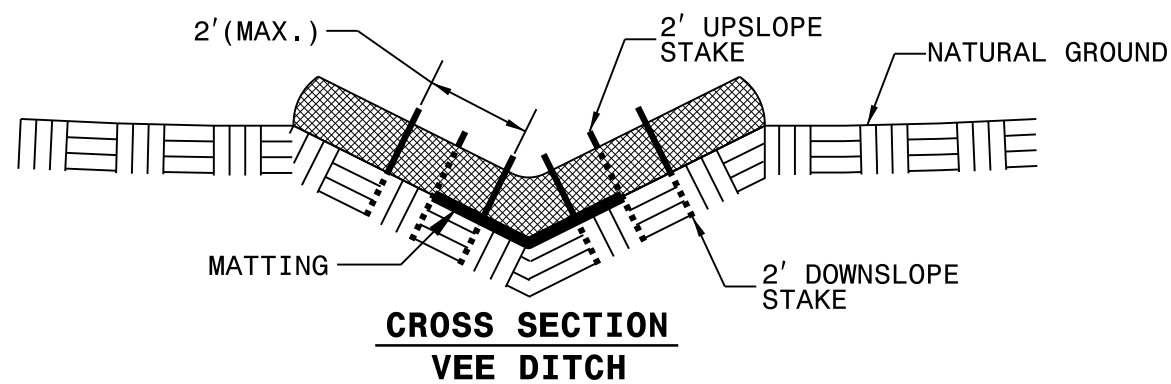
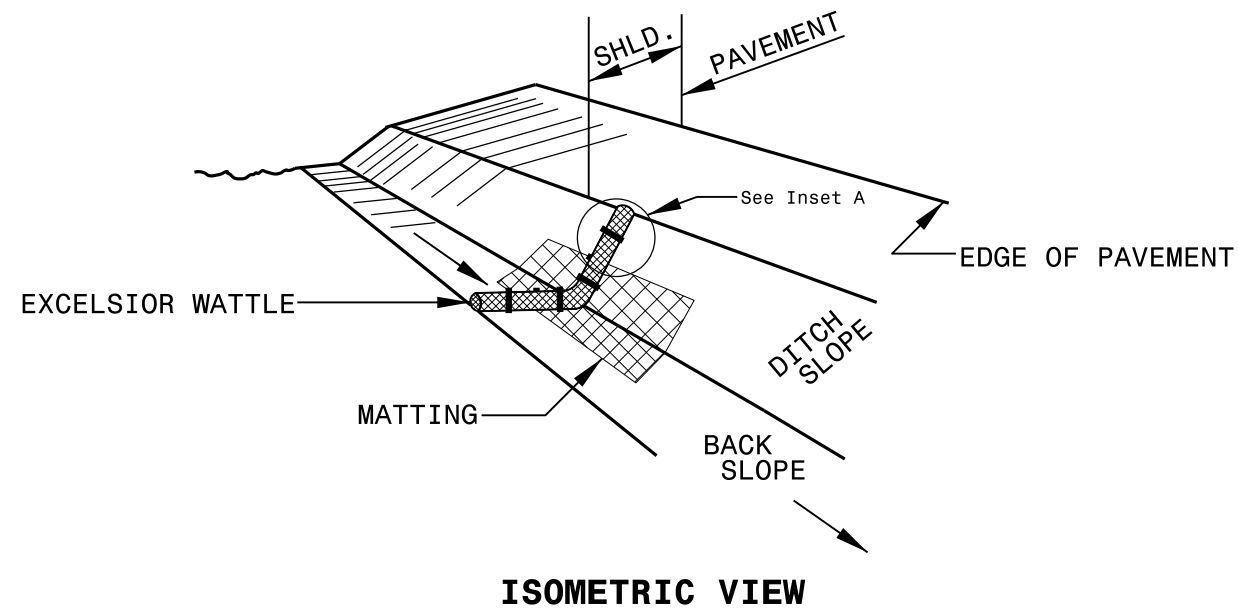

NOTES:

USE MINIMUM 12 IN. DIAMETER EXCELSIOR WATTLE.

USE 2 FT. WOODEN STAKES WITH A 2 IN. BY 2 IN. NOMINAL CROSS SECTION.

ONLY INSTALL WATTLE(S) TO A HEIGHT IN DITCH SO FLOW WILL NOT WASH AROUND WATTLE AND SCOUR DITCH SLOPES AND AS DIRECTED.

INSTALL A MINIMUM OF 2 UPSLOPE STAKES AND 4 DOWNSLOPE STAKES AT AN ANGLE TO WEDGE WATTLE TO BOTTOM OF DITCH.

PROVIDE STAPLES MADE OF 0.125 IN. DIAMETER STEEL WIRE FORMED INTO A U SHAPE NOT LESS THAN 12" IN LENGTH.

INSTALL STAPLES APPROXIMATELY EVERY 1 LINEAR FOOT ON BOTH SIDES OF WATTLE AND AT EACH END TO SECURE IT TO THE SOIL.

INSTALL MATTING IN ACCORDANCE WITH SECTION 1631 OF THE STANDARD SPECIFICATIONS.

PRIOR TO POLYACRYLAMIDE (PAM) APPLICATION, OBTAIN A SOIL SAMPLE FROM PROJECT LOCATION, AND FROM OFFSITE MATERIAL, AND ANALYZE FOR APPROPRIATE PAM FLOCCULANT TO BE APPLIED TO EACH WATTLE.

INITIALLY APPLY 2 OUNCES OF ANIONIC OR NEUTRALLY CHARGED PAM OVER WATTLE WHERE WATER WILL FLOW AND 1 OUNCE OF PAM ON MATTING ON EACH SIDE OF WATTLE. REAPPLY PAM AFTER EVERY RAINFALL EVENT THAT IS EQUAL TO OR EXCEEDS 0.50 IN.

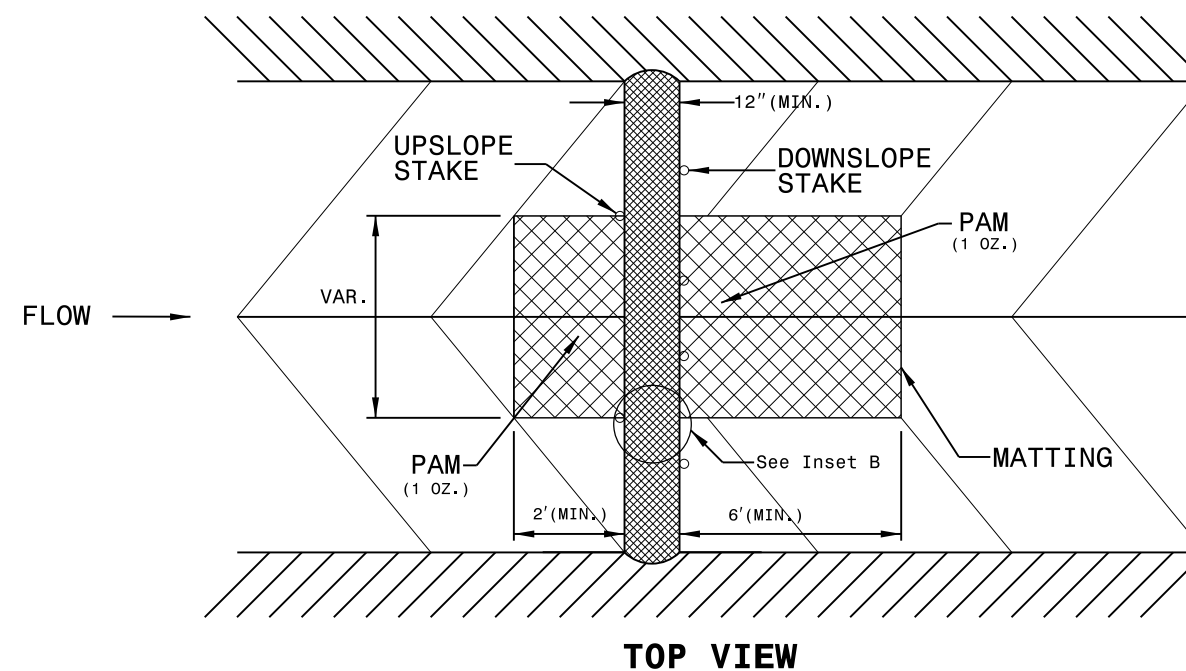
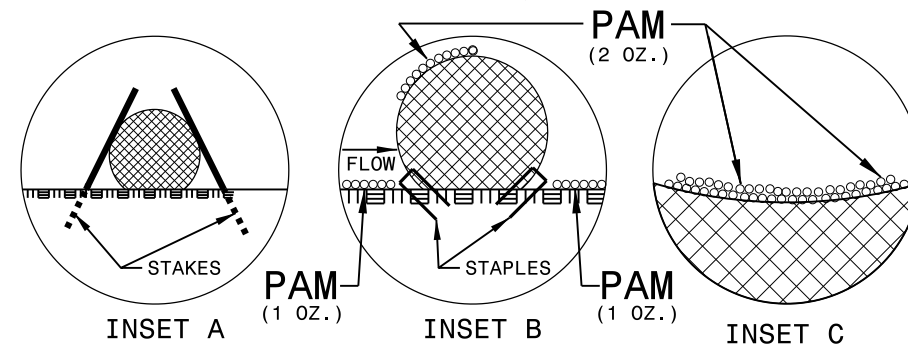

MATTING INSTALLATION DETAIL

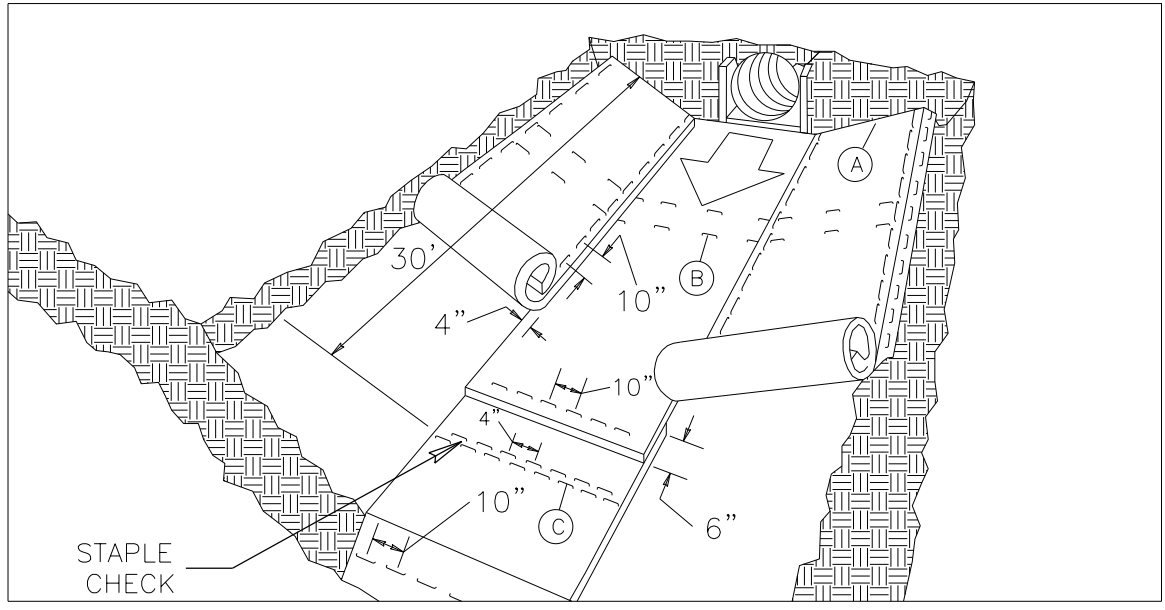

MATTING IN DITCHES

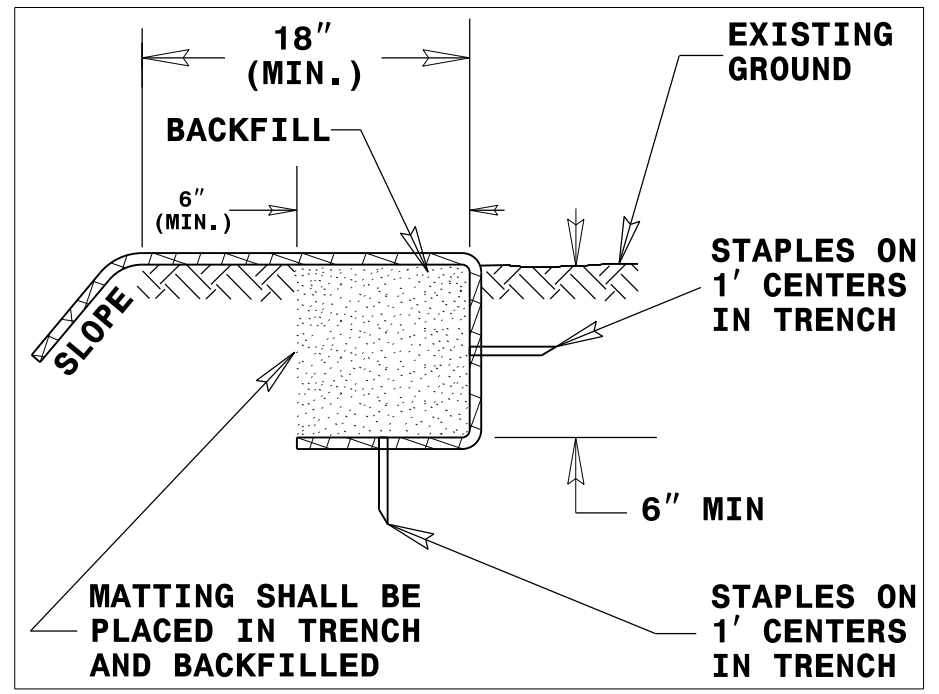
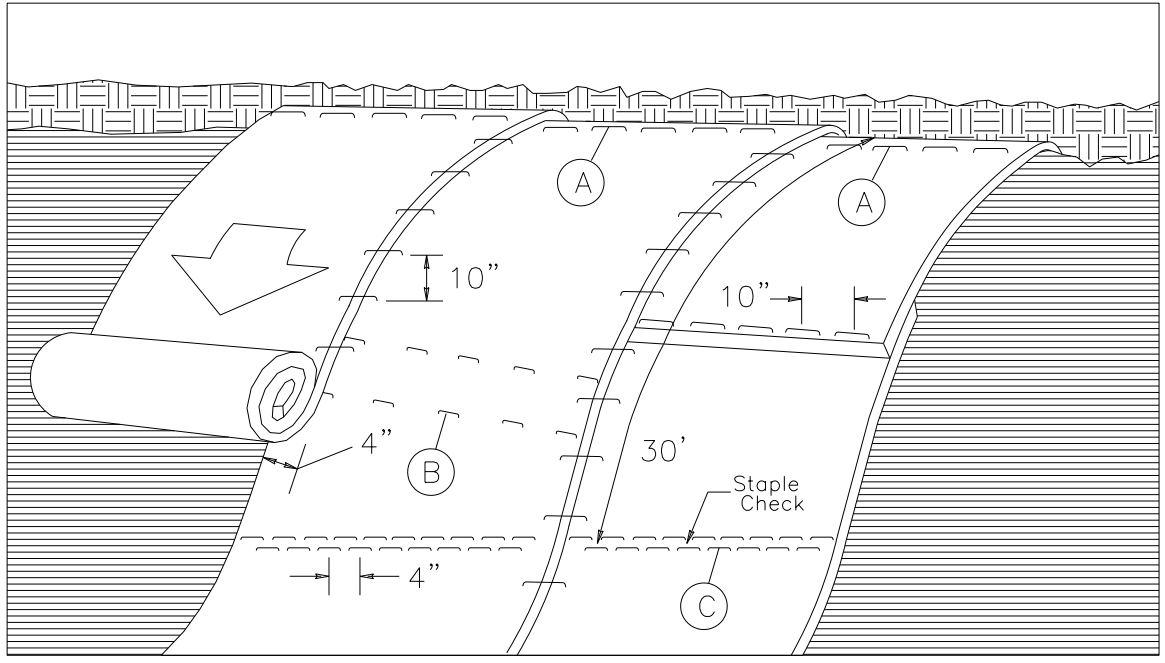

DIAGRAM (A)



MATTING ON SLOPES

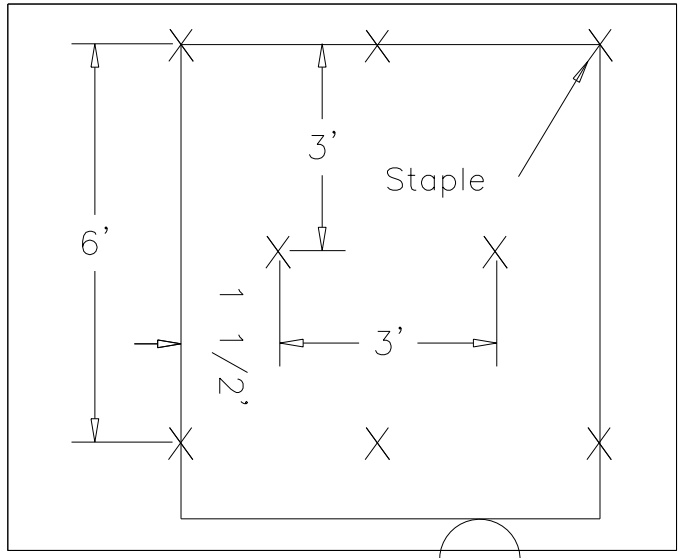

DIAGRAM B

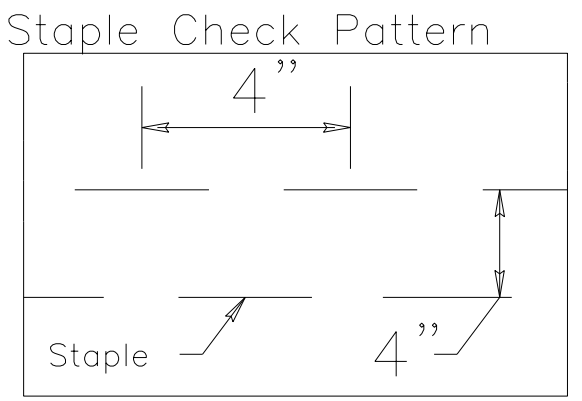

DIAGRAM (C)

NOTES:
 THIS DETAIL APPLIES TO STRAW, EXCELSIOR, AND PERMANENT SOIL REINFORCEMENT MAT (PSRM) INSTALLATION.
 STAPLES SHALL BE NO. 11 GAUGE STEEL WIRE FORMED INTO A "U" SHAPE WITH A MINIMUM THROAT WIDTH OF 1 INCH AND NOT LESS THAN 6 INCHES IN LENGTH.

NOT TO SCALE

GENERAL NOTES:

USE NO. 5 OR NO. 57 STONE FOR SEDIMENT CONTROL STONE.

USE HARDWARE CLOTH 24 GAUGE WIRE MESH WITH 1/4 INCH MESH OPENINGS.

INSTALL 5 FT. SELF FASTENER ANGLE STEEL POST 2 FT. DEEP MINIMUM.

SPACE POST A MAXIMUM OF 3 FT.

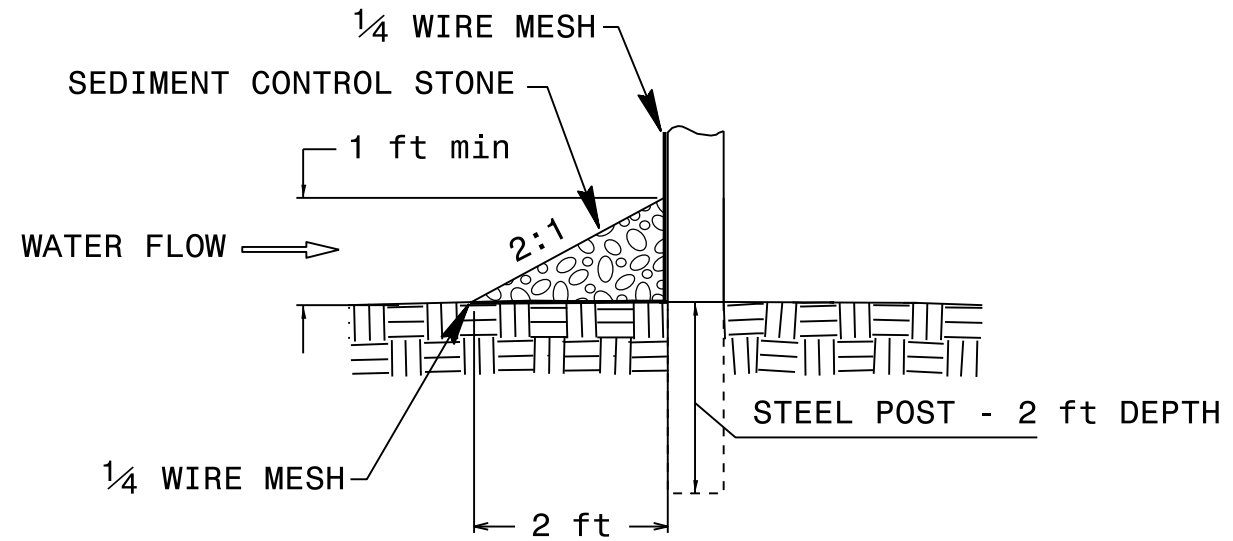
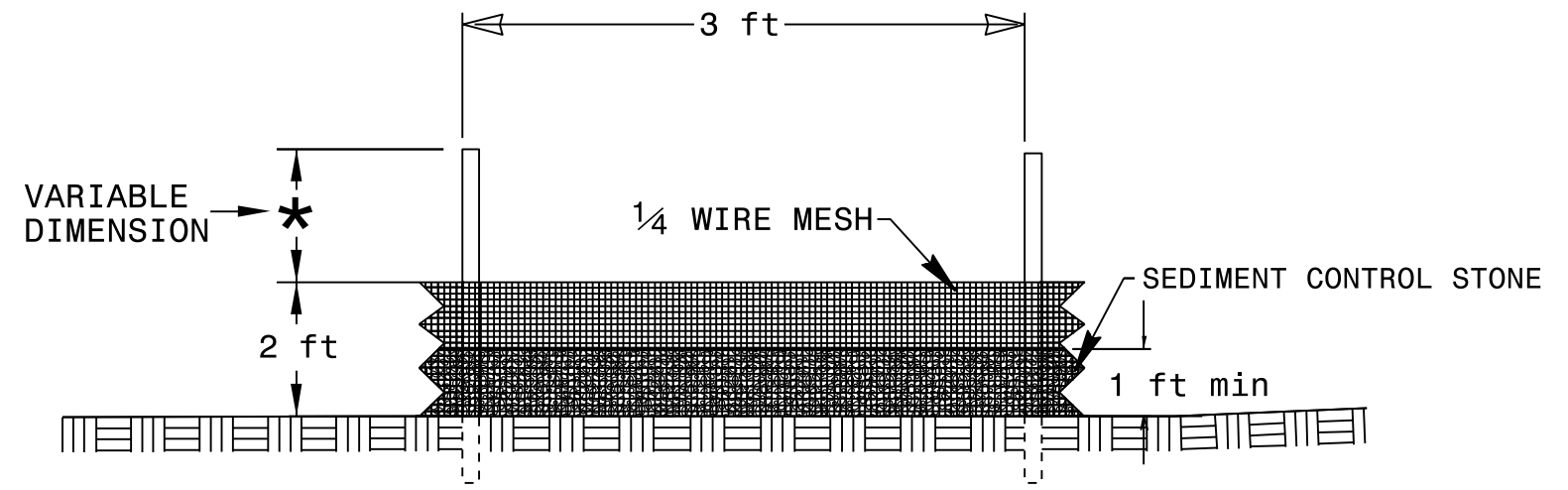

STATE OF NORTH CAROLINA
DEPT. OF TRANSPORTATION
DIVISION OF HIGHWAYS
RALEIGH, N.C.

STATE OF NORTH CAROLINA
DEPT. OF TRANSPORTATION
DIVISION OF HIGHWAYS
RALEIGH, N.C.

7-06

7-06

ENGLISH STANDARD DRAWING FOR
GRAVEL CONSTRUCTION ENTRANCE

ENGLISH STANDARD DRAWING FOR
GRAVEL CONSTRUCTION ENTRANCE

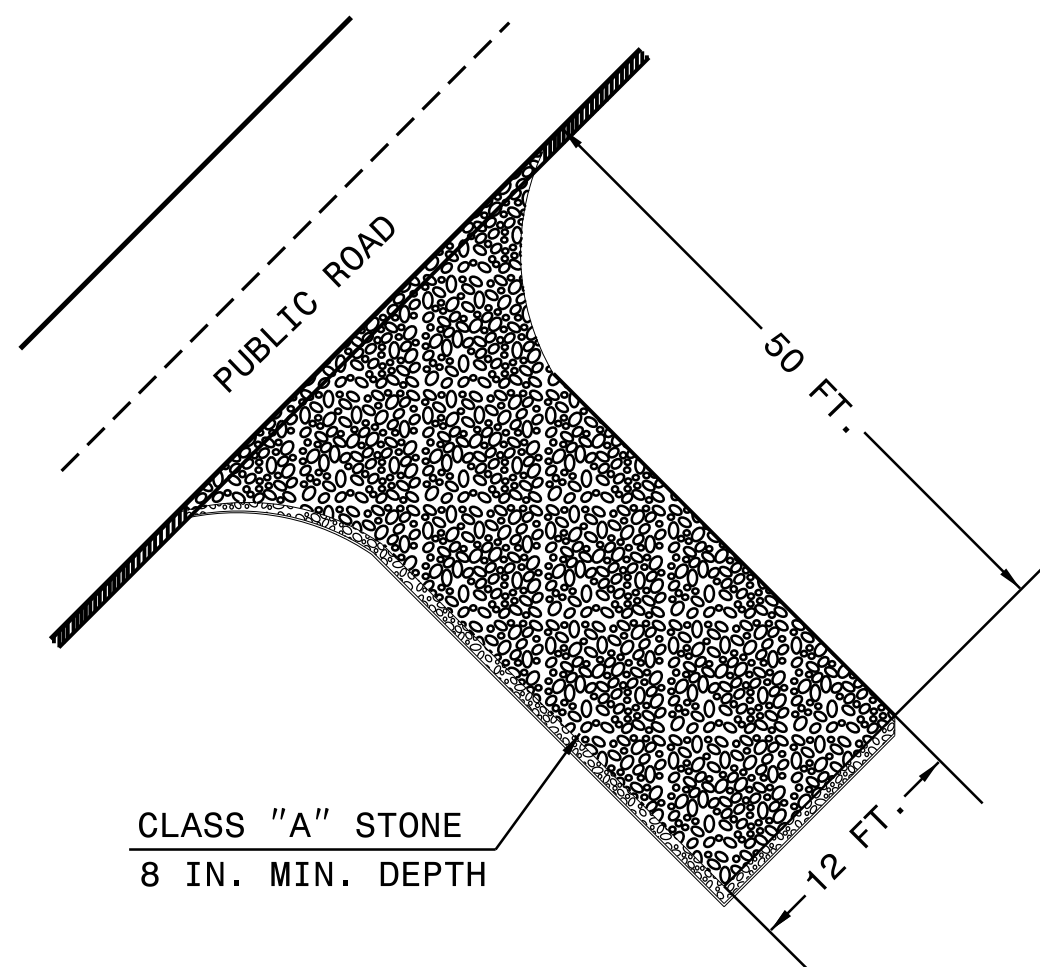

- NOTES:
1. PROVIDE TURNING RADIUS SUFFICIENT TO ACCOMMODATE LARGE TRUCKS.
 2. LOCATE ENTRANCE(S) TO PROVIDE FOR UTILIZATION BY ALL CONSTRUCTION VEHICLES.
 3. MUST BE MAINTAINED IN A CONDITION WHICH WILL PREVENT TRACKING OR DIRECT FLOW OF MUD ONTO STREETS. PERIODIC TOPDRESSING WITH STONE WILL BE NECESSARY.
 4. ANY MATERIAL TRACKED ONTO THE ROADWAY MUST BE CLEANED UP IMMEDIATELY.
 5. LOCATE GRAVEL CONSTRUCTION ENTRANCE AT ALL POINTS OF INGRESS AND EGRESS UNTIL SITE IS STABILIZED. PROVIDE FREQUENT CHECKS OF THE DEVICE AND TIMELY MAINTENANCE.
 6. NUMBER AND LOCATION OF CONSTRUCTION ENTRANCES TO BE DETERMINED BY THE ENGINEER.
 7. USE CLASS 'A' STONE OR OTHER COARSE AGGREGATE APPROVED BY THE ENGINEER.

NOTE: PLACE FILTER FABRIC BENEATH STONE